



General Description

The AME8800/8811 family of positive, linear regulators feature low quiescent current (30µA typ.) with low drop-out voltage, making them ideal for battery applications. The space-saving SOT-23, SOT-25, SOT-89 and TO-92 packages are attractive for "Pocket" and "Hand Held" applications.

These rugged devices have both Thermal Shutdown, and Current Fold-back to prevent device failure under the "Worst" of operating conditions.

The AME8800/8811 is stable with an output capacitance of 2.2µF or greater.

Features

- Very Low Dropout Voltage
- Guaranteed 300mA Output
- Accurate to within 1.5%
- 30µA Quiescent Current
- Over-Temperature Shutdown
- Current Limiting
- Short Circuit Current Fold-back
- Space-Saving SOT-23, SOT-25, SOT-89 and TO-92 Packages
- Factory Pre-set Output Voltages
- Low Temperature Coefficient
- All AME's Lead Free Product Meet RoHS Standards

Applications

- Instrumentation
- Portable Electronics
- Wireless Devices
- Cordless Phones
- PC Peripherals
- Battery Powered Widgets
- Electronic Scales

Functional Block Diagram

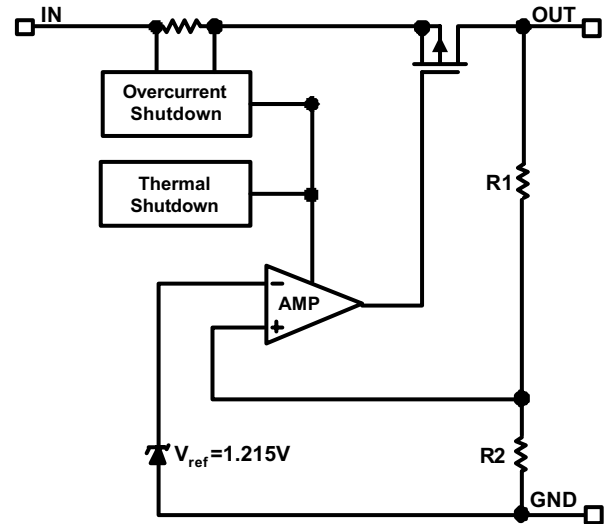

Typical Application

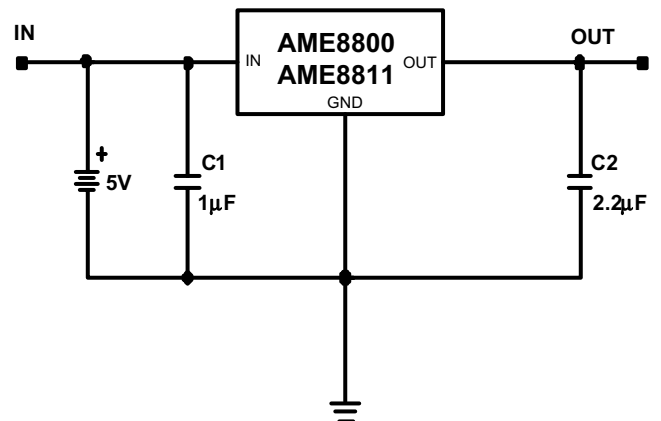

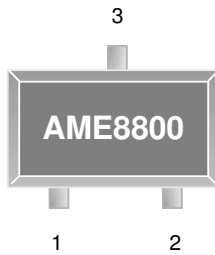
■ Pin Configuration
**SOT-23
Top View**

AME8800

1. GND
2. V_{OUT}
3. V_{IN}

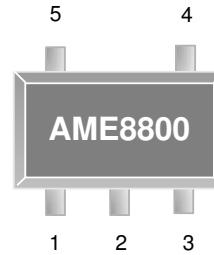
***Die Attach:
Non-Conductive Epoxy**

**SOT-25
Top View**

AME8800

1. GND
2. V_{IN}
3. V_{OUT}
4. NC
5. NC

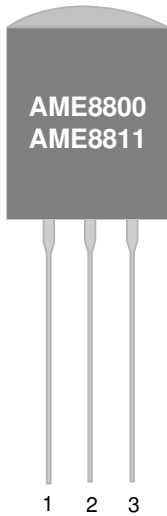
***Die Attach:
Non-Conductive Epoxy**

**TO-92
Front View**

AME8800

1. GND
2. V_{IN}
3. V_{OUT}

***Die Attach:
Non-Conductive Epoxy**

AME8811

1. V_{OUT}
2. GND
3. V_{IN}

***Die Attach:
Conductive Epoxy**

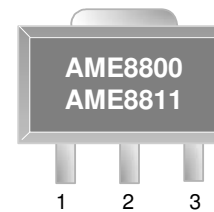
**SOT-89
Top View**

AME8800

1. GND
2. V_{IN}
3. V_{OUT}

***Die Attach:
Non-Conductive Epoxy**

AME8811

1. V_{OUT}
2. GND
3. V_{IN}

***Die Attach:
Non-Conductive Epoxy**



■ Ordering Information

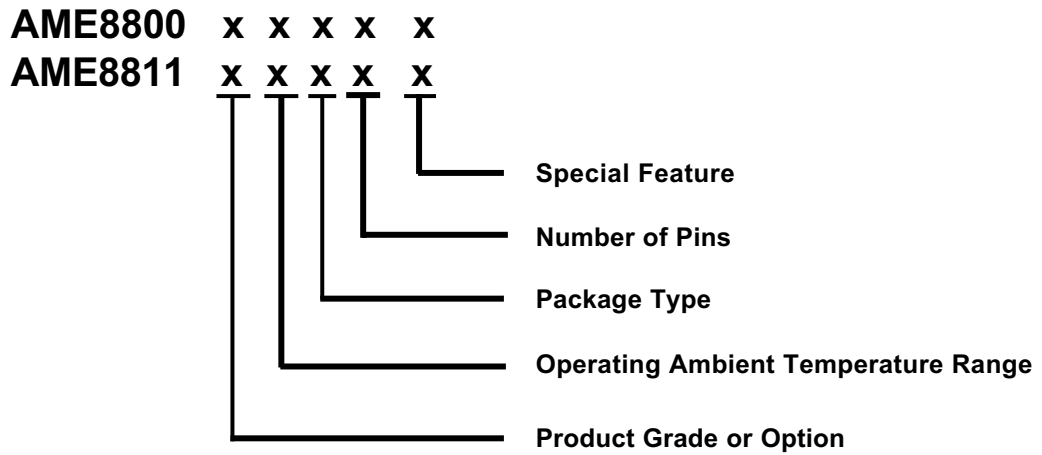

Product Grade or Option	Operating Ambient Temperature Range	Package Type	Number of Pins	Special Feature
A: 3.3V 1: 1.3V B: 3.0V 2: 2.0V C: 2.8V 3: 4.2V D: 2.5V 4: 4.0V E: 3.8V F: 3.6V G: 3.5V H: 2.7V I: 3.4V J: 2.85V K: 3.7V L: 1.5V M: 1.8V N: 2.9V O: 3.1V P: 4.1V Q: 4.75V R: 2.65V S: 5.0V U: 3.2V V: 3.15V W: 2.3V Y: 1.9V Z: 1.7V	E: -40°C to 85°C	A: TO-92 E: SOT-2X F: SOT-89	T: 3 V: 5	L: Low Profile Y: Lead Free & Low Profile Z: Lead Free



■ **Ordering Information (contd.)**

Part Number	Marking*	Output Voltage	Package	Operating Ambient Temperature Range
AME88004EET	BDBww	4.0V	SOT-23	- 40°C to + 85°C
AME88004EETL	BDBww	4.0V	SOT-23-L	- 40°C to + 85°C
AME88004EETY	BDBww	4.0V	SOT-23-L	- 40°C to + 85°C
AME88004EETZ	BDBww	4.0V	SOT-23	- 40°C to + 85°C
AME8800AEET	AAAww	3.3V	SOT-23	- 40°C to + 85°C
AME8800AEETL	AAAww	3.3V	SOT-23-L	- 40°C to + 85°C
AME8800AEETY	AAAww	3.3V	SOT-23-L	- 40°C to + 85°C
AME8800AEETZ	AAAww	3.3V	SOT-23	- 40°C to + 85°C
AME8800BEET	AABww	3.0V	SOT-23	- 40°C to + 85°C
AME8800BEETL	AABww	3.0V	SOT-23-L	- 40°C to + 85°C
AME8800BEETZ	AABww	3.0V	SOT-23	- 40°C to + 85°C
AME8800BEETY	AABww	3.0V	SOT-23-L	- 40°C to + 85°C
AME8800CEET	AACww	2.8V	SOT-23	- 40°C to + 85°C
AME8800CEETL	AACww	2.8V	SOT-23-L	- 40°C to + 85°C
AME8800CEETZ	AACww	2.8V	SOT-23	- 40°C to + 85°C
AME8800CEETY	AACww	2.8V	SOT-23-L	- 40°C to + 85°C
AME8800DEET	AADww	2.5V	SOT-23	- 40°C to + 85°C
AME8800DEETL	AADww	2.5V	SOT-23-L	- 40°C to + 85°C
AME8800DEETZ	AADww	2.5V	SOT-23	- 40°C to + 85°C
AME8800DEETY	AADww	2.5V	SOT-23-L	- 40°C to + 85°C
AME8800EEET	AAEww	3.8V	SOT-23	- 40°C to + 85°C
AME8800EEETL	AAEww	3.8V	SOT-23-L	- 40°C to + 85°C
AME8800EEETZ	AAEww	3.8V	SOT-23	- 40°C to + 85°C
AME8800EEETY	AAEww	3.8V	SOT-23-L	- 40°C to + 85°C
AME8800FEET	ABNww	3.6V	SOT-23	- 40°C to + 85°C
AME8800FEETL	ABNww	3.6V	SOT-23-L	- 40°C to + 85°C
AME8800FEETZ	ABNww	3.6V	SOT-23	- 40°C to + 85°C
AME8800FEETY	ABNww	3.6V	SOT-23-L	- 40°C to + 85°C

■ Ordering Information (contd.)

Part Number	Marking*	Output Voltage	Package	Operating Ambient Temperature Range
AME8800GEET	ACDww	3.5V	SOT-23	- 40°C to + 85°C
AME8800GEETL	ACDww	3.5V	SOT-23-L	- 40°C to + 85°C
AME8800GEETZ	ACDww	3.5V	SOT-23	- 40°C to + 85°C
AME8800GEETY	ACDww	3.5V	SOT-23-L	- 40°C to + 85°C
AME8800HEET	AEDww	2.7V	SOT-23	- 40°C to + 85°C
AME8800HEETL	AEDww	2.7V	SOT-23-L	- 40°C to + 85°C
AME8800HEETZ	AEDww	2.7V	SOT-23	- 40°C to + 85°C
AME8800HEETY	AEDww	2.7V	SOT-23-L	- 40°C to + 85°C
AME8800IEET	AELww	3.4V	SOT-23	- 40°C to + 85°C
AME8800IEETL	AELww	3.4V	SOT-23-L	- 40°C to + 85°C
AME8800IEETZ	AELww	3.4V	SOT-23	- 40°C to + 85°C
AME8800IEETY	AELww	3.4V	SOT-23-L	- 40°C to + 85°C
AME8800JEET	AGNww	2.85V	SOT-23	- 40°C to + 85°C
AME8800JEETL	AGNww	2.85V	SOT-23-L	- 40°C to + 85°C
AME8800JEETZ	AGNww	2.85V	SOT-23	- 40°C to + 85°C
AME8800JEETY	AGNww	2.85V	SOT-23-L	- 40°C to + 85°C
AME8800KEET	AHPww	3.7V	SOT-23	- 40°C to + 85°C
AME8800KEETL	AHPww	3.7V	SOT-23-L	- 40°C to + 85°C
AME8800KEETZ	AHPww	3.7V	SOT-23	- 40°C to + 85°C
AME8800KEETY	AHPww	3.7V	SOT-23-L	- 40°C to + 85°C
AME8800LEET	AJWww	1.5V	SOT-23	- 40°C to + 85°C
AME8800LEETL	AJWww	1.5V	SOT-23-L	- 40°C to + 85°C
AME8800LEETZ	AJWww	1.5V	SOT-23	- 40°C to + 85°C
AME8800LEETY	AJWww	1.5V	SOT-23-L	- 40°C to + 85°C
AME8800MEET	AJXww	1.8V	SOT-23	- 40°C to + 85°C
AME8800MEETL	AJXww	1.8V	SOT-23-L	- 40°C to + 85°C
AME8800MEETZ	AJXww	1.8V	SOT-23	- 40°C to + 85°C
AME8800MEETY	AJXww	1.8V	SOT-23-L	- 40°C to + 85°C

■ Ordering Information (contd.)

Part Number	Marking*	Output Voltage	Package	Operating Ambient Temperature Range
AME8800NEET	AKGww	2.9V	SOT-23	- 40°C to + 85°C
AME8800NEETL	AKGww	2.9V	SOT-23-L	- 40°C to + 85°C
AME8800NEETZ	AKGww	2.9V	SOT-23	- 40°C to + 85°C
AME8800NEETY	AKGww	2.9V	SOT-23-L	- 40°C to + 85°C
AME8800OEET	AKHww	3.1V	SOT-23	- 40°C to + 85°C
AME8800OEETL	AKHww	3.1V	SOT-23-L	- 40°C to + 85°C
AME8800OEETZ	AKHww	3.1V	SOT-23	- 40°C to + 85°C
AME8800OEETY	AKHww	3.1V	SOT-23-L	- 40°C to + 85°C
AME8800AEEV	ABRww	3.3V	SOT-25	- 40°C to + 85°C
AME8800AEEVL	ABRww	3.3V	TSOT-25	- 40°C to + 85°C
AME8800AEEVZ	ABRww	3.3V	SOT-25	- 40°C to + 85°C
AME8800AEEVY	ABRww	3.3V	TSOT-25	- 40°C to + 85°C
AME8800BEEV	ABSww	3.0V	SOT-25	- 40°C to + 85°C
AME8800BEEVL	ABSww	3.0V	TSOT-25	- 40°C to + 85°C
AME8800BEEVZ	ABSww	3.0V	SOT-25	- 40°C to + 85°C
AME8800BEEVY	ABSww	3.0V	TSOT-25	- 40°C to + 85°C
AME8800CEEV	ABTww	2.8V	SOT-25	- 40°C to + 85°C
AME8800CEEVL	ABTww	2.8V	TSOT-25	- 40°C to + 85°C
AME8800CEEVZ	ABTww	2.8V	SOT-25	- 40°C to + 85°C
AME8800CEEVY	ABTww	2.8V	TSOT-25	- 40°C to + 85°C
AME8800DEEV	ABUww	2.5V	SOT-25	- 40°C to + 85°C
AME8800DEEVL	ABUww	2.5V	TSOT-25	- 40°C to + 85°C
AME8800DEEVZ	ABUww	2.5V	SOT-25	- 40°C to + 85°C
AME8800DEEVY	ABUww	2.5V	TSOT-25	- 40°C to + 85°C
AME8800EEEV	ABVww	3.8V	SOT-25	- 40°C to + 85°C
AME8800EEEVL	ABVww	3.8V	TSOT-25	- 40°C to + 85°C
AME8800EEEVZ	ABVww	3.8V	SOT-25	- 40°C to + 85°C
AME8800EEEVY	ABVww	3.8V	TSOT-25	- 40°C to + 85°C

■ Ordering Information (contd.)

Part Number	Marking*	Output Voltage	Package	Operating Ambient Temperature Range
AME8800FEEV	ABWww	3.6V	SOT-25	- 40°C to + 85°C
AME8800FEEVL	ABWww	3.6V	TSOT-25	- 40°C to + 85°C
AME8800FEEVZ	ABWww	3.6V	SOT-25	- 40°C to + 85°C
AME8800FEEVY	ABWww	3.6V	TSOT-25	- 40°C to + 85°C
AME8800GEEV	ACEww	3.5V	SOT-25	- 40°C to + 85°C
AME8800GEEVL	ACEww	3.5V	TSOT-25	- 40°C to + 85°C
AME8800GEEVZ	ACEww	3.5V	SOT-25	- 40°C to + 85°C
AME8800GEEVY	ACEww	3.5V	TSOT-25	- 40°C to + 85°C
AME8800HEEV	AEEww	2.7V	SOT-25	- 40°C to + 85°C
AME8800HEEVL	AEEww	2.7V	TSOT-25	- 40°C to + 85°C
AME8800HEEVZ	AEEww	2.7V	SOT-25	- 40°C to + 85°C
AME8800HEEVY	AEEww	2.7V	TSOT-25	- 40°C to + 85°C
AME8800IEEV	AEMww	3.4V	SOT-25	- 40°C to + 85°C
AME8800IEEVL	AEMww	3.4V	TSOT-25	- 40°C to + 85°C
AME8800IEEVZ	AEMww	3.4V	SOT-25	- 40°C to + 85°C
AME8800IEEVY	AEMww	3.4V	TSOT-25	- 40°C to + 85°C
AME8800JEEV	AGOww	2.85V	SOT-25	- 40°C to + 85°C
AME8800JEEVL	AGOww	2.85V	TSOT-25	- 40°C to + 85°C
AME8800JEEVZ	AGOww	2.85V	SOT-25	- 40°C to + 85°C
AME8800JEEVY	AGOww	2.85V	TSOT-25	- 40°C to + 85°C
AME8800KEEV	AHQww	3.7V	SOT-25	- 40°C to + 85°C
AME8800KEEVL	AHQww	3.7V	TSOT-25	- 40°C to + 85°C
AME8800KEEVZ	AHQww	3.7V	SOT-25	- 40°C to + 85°C
AME8800KEEVY	AHQww	3.7V	TSOT-25	- 40°C to + 85°C
AME8800LEEV	AJUww	1.5V	SOT-25	- 40°C to + 85°C
AME8800LEEVL	AJUww	1.5V	TSOT-25	- 40°C to + 85°C
AME8800LEEVS	AJUww	1.5V	SOT-25	- 40°C to + 85°C
AME8800LEEVS	AJUww	1.5V	TSOT-25	- 40°C to + 85°C

■ Ordering Information (contd.)

Part Number	Marking*	Output Voltage	Package	Operating Ambient Temperature Range
AME8800MEEV	AJVww	1.8V	SOT-25	- 40°C to + 85°C
AME8800MEEVL	AJVww	1.8V	TSOT-25	- 40°C to + 85°C
AME8800MEEVZ	AJVww	1.8V	SOT-25	- 40°C to + 85°C
AME8800MEEVY	AJVww	1.8V	TSOT-25	- 40°C to + 85°C
AME8800NEEV	AKlww	2.9V	SOT-25	- 40°C to + 85°C
AME8800NEEVL	AKlww	2.9V	TSOT-25	- 40°C to + 85°C
AME8800NEEVZ	AKlww	2.9V	SOT-25	- 40°C to + 85°C
AME8800NEEVY	AKlww	2.9V	TSOT-25	- 40°C to + 85°C
AME8800OEEV	AKJww	3.1V	SOT-25	- 40°C to + 85°C
AME8800OEEVL	AKJww	3.1V	TSOT-25	- 40°C to + 85°C
AME8800OEEVZ	AKJww	3.1V	SOT-25	- 40°C to + 85°C
AME8800OEEVY	AKJww	3.1V	TSOT-25	- 40°C to + 85°C
AME8800AEFT	A8800 AEFww	3.3V	SOT-89	- 40°C to + 85°C
AME8800AEFTZ	A8800 AEFww	3.3V	SOT-89	- 40°C to + 85°C
AME8800BEFT	A8800 BEFww	3.0V	SOT-89	- 40°C to + 85°C
AME8800BEFTZ	A8800 BEFww	3.0V	SOT-89	- 40°C to + 85°C
AME8800CEFT	A8800 CEFww	2.8V	SOT-89	- 40°C to + 85°C
AME8800CEFTZ	A8800 CEFww	2.8V	SOT-89	- 40°C to + 85°C
AME8800DEFT	A8800 DEFww	2.5V	SOT-89	- 40°C to + 85°C
AME8800DEFTZ	A8800 DEFww	2.5V	SOT-89	- 40°C to + 85°C
AME8800EEFT	A8800 EEFww	3.8V	SOT-89	- 40°C to + 85°C
AME8800EEFTZ	A8800 EEFww	3.8V	SOT-89	- 40°C to + 85°C
AME8800FEFT	A8800 FEFww	3.6V	SOT-89	- 40°C to + 85°C
AME8800FEFTZ	A8800 FEFww	3.6V	SOT-89	- 40°C to + 85°C

■ Ordering Information (contd.)

Part Number	Marking*	Output Voltage	Package	Operating Ambient Temperature Range
AME8800GEFT	A8800 GEFww	3.5V	SOT-89	- 40°C to + 85°C
AME8800GEFTZ	A8800 GEFww	3.5V	SOT-89	- 40°C to + 85°C
AME8800HEFT	A8800 HEFww	2.7V	SOT-89	- 40°C to + 85°C
AME8800HEFTZ	A8800 HEFww	2.7V	SOT-89	- 40°C to + 85°C
AME8800IEFT	A8800 IEFww	3.4V	SOT-89	- 40°C to + 85°C
AME8800IEFTZ	A8800 IEFww	3.4V	SOT-89	- 40°C to + 85°C
AME8800JEFT	A8800 JEFww	2.85V	SOT-89	- 40°C to + 85°C
AME8800JEFTZ	A8800 JEFww	2.85V	SOT-89	- 40°C to + 85°C
AME8800KEFT	A8800 KEFww	3.7V	SOT-89	- 40°C to + 85°C
AME8800KEFTZ	A8800 KEFww	3.7V	SOT-89	- 40°C to + 85°C
AME8800LEFT	A8800 LEFww	1.5V	SOT-89	- 40°C to + 85°C
AME8800LEFTZ	A8800 LEFww	1.5V	SOT-89	- 40°C to + 85°C
AME8800MEFT	A8800 MEFww	1.8V	SOT-89	- 40°C to + 85°C
AME8800MEFTZ	A8800 MEFww	1.8V	SOT-89	- 40°C to + 85°C
AME8800NEFT	A8800 NEFww	2.9V	SOT-89	- 40°C to + 85°C
AME8800NEFTZ	A8800 NEFww	2.9V	SOT-89	- 40°C to + 85°C
AME8800OEFT	A8800 OEFww	3.1V	SOT-89	- 40°C to + 85°C
AME8800OEFTZ	A8800 OEFww	3.1V	SOT-89	- 40°C to + 85°C
AME8800SEFT	A8800 SEFww	5.0V	SOT-89	- 40°C to + 85°C
AME8800SEFTZ	A8800 SEFww	5.0V	SOT-89	- 40°C to + 85°C
AME8800WEFT	A8800 WEFww	2.3V	SOT-89	- 40°C to + 85°C
AME8800WEFTZ	A8800 WEFww	2.3V	SOT-89	- 40°C to + 85°C

■ Ordering Information (contd.)

Part Number	Marking*	Output Voltage	Package	Operating Ambient Temperature Range
AME8800ZEFT	A8800 ZEFww	1.7V	SOT-89	- 40°C to + 85°C
AME8800ZEFTZ	A8800 ZEFww	1.7V	SOT-89	- 40°C to + 85°C
AME88001EFT	A8800 1EFww	1.3V	SOT-89	- 40°C to + 85°C
AME88001EFTZ	A8800 1EFww	1.3V	SOT-89	- 40°C to + 85°C
AME88002EFT	A8800 2EFww	2.0V	SOT-89	- 40°C to + 85°C
AME88002EFTZ	A8800 2EFww	2.0V	SOT-89	- 40°C to + 85°C
AME88003EFT	A8800 3EFww	4.2V	SOT-89	- 40°C to + 85°C
AME88003EFTZ	A8800 3EFww	4.2V	SOT-89	- 40°C to + 85°C
AME88004EFT	A8800 4EFww	4.0V	SOT-89	- 40°C to + 85°C
AME88004EFTZ	A8800 4EFww	4.0V	SOT-89	- 40°C to + 85°C

■ Ordering Information (contd.)

Part Number	Marking*	Output Voltage	Package	Operating Ambient Temperature Range
AME8800AEAT	AME 8800 AEAT yyww	3.3V	TO-92	- 40°C to + 85°C
AME8800AEATZ	AME 8800 AEAT yyww	3.3V	TO-92	- 40°C to + 85°C
AME8800BEAT	AME 8800 BEAT yyww	3.0V	TO-92	- 40°C to + 85°C
AME8800BEATZ	AME 8800 BEAT yyww	3.0V	TO-92	- 40°C to + 85°C
AME8800CEAT	AME 8800 CEAT yyww	2.8V	TO-92	- 40°C to + 85°C
AME8800CEATZ	AME 8800 CEAT yyww	2.8V	TO-92	- 40°C to + 85°C
AME8800DEAT	AME 8800 DEAT yyww	2.5V	TO-92	- 40°C to + 85°C
AME8800DEATZ	AME 8800 DEAT yyww	2.5V	TO-92	- 40°C to + 85°C
AME8800EEAT	AME 8800 EEAT yyww	3.8V	TO-92	- 40°C to + 85°C
AME8800EEATZ	AME 8800 EEAT yyww	3.8V	TO-92	- 40°C to + 85°C



■ Ordering Information (contd.)

Part Number	Marking*	Output Voltage	Package	Operating Ambient Temperature Range
AME8800FEAT	AME 8800 FEAT yyww	3.6V	TO-92	- 40°C to + 85°C
AME8800FEATZ	AME 8800 FEAT yyww	3.6V	TO-92	- 40°C to + 85°C
AME8800GEAT	AME 8800 GEAT yyww	3.5V	TO-92	- 40°C to + 85°C
AME8800GEATZ	AME 8800 GEAT yyww	3.5V	TO-92	- 40°C to + 85°C
AME8800HEAT	AME 8800 HEAT yyww	2.7V	TO-92	- 40°C to + 85°C
AME8800HEATZ	AME 8800 HEAT yyww	2.7V	TO-92	- 40°C to + 85°C
AME8800IEAT	AME 8800 IEAT yyww	3.4V	TO-92	- 40°C to + 85°C
AME8800IEATZ	AME 8800 IEAT yyww	3.4V	TO-92	- 40°C to + 85°C
AME8800JEAT	AME 8800 JEAT yyww	2.85V	TO-92	- 40°C to + 85°C
AME8800JEATZ	AME 8800 JEAT yyww	2.85V	TO-92	- 40°C to + 85°C

■ Ordering Information (contd.)

Part Number	Marking*	Output Voltage	Package	Operating Ambient Temperature Range
AME8800KEAT	AME 8800 KEAT yyww	3.7V	TO-92	- 40°C to + 85°C
AME8800KEATZ	AME 8800 KEAT yyww	3.7V	TO-92	- 40°C to + 85°C
AME8800LEAT	AME 8800 LEAT yyww	1.5V	TO-92	- 40°C to + 85°C
AME8800LEATZ	AME 8800 LEAT yyww	1.5V	TO-92	- 40°C to + 85°C
AME8800MEAT	AME 8800 MEAT yyww	1.8V	TO-92	- 40°C to + 85°C
AME8800MEATZ	AME 8800 MEAT yyww	1.8V	TO-92	- 40°C to + 85°C
AME8800NEAT	AME 8800 NEAT yyww	2.9V	TO-92	- 40°C to + 85°C
AME8800NEATZ	AME 8800 NEAT yyww	2.9V	TO-92	- 40°C to + 85°C
AME8800OEAT	AME 8800 OEAT yyww	3.1V	TO-92	- 40°C to + 85°C
AME8800OEATZ	AME 8800 OEAT yyww	3.1V	TO-92	- 40°C to + 85°C



■ Ordering Information (contd.)

Part Number	Marking*	Output Voltage	Package	Operating Ambient Temperature Range
AME8811AEAT	AME 8811 AEAT yyww	3.3V	TO-92	- 40°C to + 85°C
AME8811AEATZ	AME 8811 AEAT yyww	3.3V	TO-92	- 40°C to + 85°C
AME8811BEAT	AME 8811 BEAT yyww	3.0V	TO-92	- 40°C to + 85°C
AME8811BEATZ	AME 8811 BEAT yyww	3.0V	TO-92	- 40°C to + 85°C
AME8811CEAT	AME 8811 CEAT yyww	2.8V	TO-92	- 40°C to + 85°C
AME8811CEATZ	AME 8811 CEAT yyww	2.8V	TO-92	- 40°C to + 85°C
AME8811DEAT	AME 8811 DEAT yyww	2.5V	TO-92	- 40°C to + 85°C
AME8811DEATZ	AME 8811 DEAT yyww	2.5V	TO-92	- 40°C to + 85°C

* Package Options

Part Number	Package	Lead Pitch
AME88xxxEAT	TO-92 Taping	5.04mm
AME88xxxEAT-1	TO-92 Bulk	2.54mm

■ Ordering Information (contd.)

Part Number	Marking*	Output Voltage	Package	Operating Ambient Temperature Range
AME8811EEAT	AME 8811 EEAT yyww	3.8V	TO-92	- 40°C to + 85°C
AME8811EEATZ	AME 8811 EEAT yyww	3.8V	TO-92	- 40°C to + 85°C
AME8811FEAT	AME 8811 FEAT yyww	3.6V	TO-92	- 40°C to + 85°C
AME8811FEATZ	AME 8811 FEAT yyww	3.6V	TO-92	- 40°C to + 85°C
AME8811GEAT	AME 8811 GEAT yyww	3.5V	TO-92	- 40°C to + 85°C
AME8811GEATZ	AME 8811 GEAT yyww	3.5V	TO-92	- 40°C to + 85°C
AME8811HEAT	AME 8811 HEAT yyww	2.7V	TO-92	- 40°C to + 85°C
AME8811HEATZ	AME 8811 HEAT yyww	2.7V	TO-92	- 40°C to + 85°C
AME8811IEAT	AME 8811 IEAT yyww	3.4V	TO-92	- 40°C to + 85°C
AME8811IEATZ	AME 8811 IEAT yyww	3.4V	TO-92	- 40°C to + 85°C

■ Ordering Information (contd.)

Part Number	Marking*	Output Voltage	Package	Operating Ambient Temperature Range
AME8811JEAT	AME 8811 JEAT yyww	2.85V	TO-92	- 40°C to + 85°C
AME8811JEATZ	AME 8811 JEAT yyww	2.85V	TO-92	- 40°C to + 85°C
AME8811KEAT	AME 8811 KEAT yyww	3.7V	TO-92	- 40°C to + 85°C
AME8811KEATZ	AME 8811 KEAT yyww	3.7V	TO-92	- 40°C to + 85°C
AME8811LEAT	AME 8811 LEAT yyww	1.5V	TO-92	- 40°C to + 85°C
AME8811LEATZ	AME 8811 LEAT yyww	1.5V	TO-92	- 40°C to + 85°C
AME8811MEAT	AME 8811 MEAT yyww	1.8V	TO-92	- 40°C to + 85°C
AME8811MEATZ	AME 8811 MEAT yyww	1.8V	TO-92	- 40°C to + 85°C
AME8811NEAT	AME 8811 NEAT yyww	2.9V	TO-92	- 40°C to + 85°C
AME8811NEATZ	AME 8811 NEAT yyww	2.9V	TO-92	- 40°C to + 85°C

■ Ordering Information (contd.)

Part Number	Marking*	Output Voltage	Package	Operating Ambient Temperature Range
AME8811OEAT	AME 8811 OEAT yyww	3.1V	TO-92	- 40°C to + 85°C
AME8811OEATZ	AME 8811 OEAT yyww	3.1V	TO-92	- 40°C to + 85°C
AME8811AEFT	A8811 AEFww	3.3V	SOT-89	- 40°C to + 85°C
AME8811AEFTZ	A8811 AEFww	3.3V	SOT-89	- 40°C to + 85°C
AME8811BEFT	A8811 BEFww	3.0V	SOT-89	- 40°C to + 85°C
AME8811BEFTZ	A8811 BEFww	3.0V	SOT-89	- 40°C to + 85°C
AME8811CEFT	A8811 CEFww	2.8V	SOT-89	- 40°C to + 85°C
AME8811CEFTZ	A8811 CEFww	2.8V	SOT-89	- 40°C to + 85°C
AME8811DEFT	A8811 DEFww	2.5V	SOT-89	- 40°C to + 85°C
AME8811DEFTZ	A8811 DEFww	2.5V	SOT-89	- 40°C to + 85°C
AME8811EEFT	A8811 EEFww	3.8V	SOT-89	- 40°C to + 85°C
AME8811EEFTZ	A8811 EEFww	3.8V	SOT-89	- 40°C to + 85°C
AME8811FEFT	A8811 FEFww	3.6V	SOT-89	- 40°C to + 85°C
AME8811FEFTZ	A8811 FEFww	3.6V	SOT-89	- 40°C to + 85°C
AME8811GEFT	A8811 GEFww	3.5V	SOT-89	- 40°C to + 85°C
AME8811GEFTZ	A8811 GEFww	3.5V	SOT-89	- 40°C to + 85°C
AME8811HEFT	A8811 HEFww	2.7V	SOT-89	- 40°C to + 85°C
AME8811HEFTZ	A8811 HEFww	2.7V	SOT-89	- 40°C to + 85°C
AME8811IEFT	A8811 IEFww	3.4V	SOT-89	- 40°C to + 85°C
AME8811IEFTZ	A8811 IEFww	3.4V	SOT-89	- 40°C to + 85°C

■ Ordering Information (contd.)

Part Number	Marking*	Output Voltage	Package	Operating Ambient Temperature Range
AME8811JEFT	A8811 JEFww	2.85V	SOT-89	- 40°C to + 85°C
AME8811JEFTZ	A8811 JEFww	2.85V	SOT-89	- 40°C to + 85°C
AME8811KEFT	A8811 KEFww	3.7V	SOT-89	- 40°C to + 85°C
AME8811KEFTZ	A8811 KEFww	3.7V	SOT-89	- 40°C to + 85°C
AME8811LEFT	A8811 LEFww	1.5V	SOT-89	- 40°C to + 85°C
AME8811LEFTZ	A8811 LEFww	1.5V	SOT-89	- 40°C to + 85°C
AME8811MEFT	A8811 MEFww	1.8V	SOT-89	- 40°C to + 85°C
AME8811MEFTZ	A8811 MEFww	1.8V	SOT-89	- 40°C to + 85°C
AME8811NEFT	A8811 NEFww	2.9V	SOT-89	- 40°C to + 85°C
AME8811NEFTZ	A8811 NEFww	2.9V	SOT-89	- 40°C to + 85°C
AME8811OEFT	A8811 OEFww	3.1V	SOT-89	- 40°C to + 85°C
AME8811OEFTZ	A8811 OEFww	3.1V	SOT-89	- 40°C to + 85°C

Note: ww & yyww represent date code and pls refer the Date Code Rule before Package Dimension.

* A line on top of the first letter represent lead free plating such as A8811

Please consult AME sales office or authorized Rep./Distributor for output voltage and package type availability.



■ Absolute Maximum Ratings

Parameter	Maximum	Unit
Input Voltage	8	V
Output Current	$P_D / (V_{IN} - V_O)$	mA
Output Voltage	GND - 0.3 to $V_{IN} + 0.3$	V
ESD Classification	B*	

Caution: Stress above the listed absolute rating may cause permanent damage to the device.

*HBM B:2000V~2999V

■ Recommended Operating Conditions

Parameter	Symbol	Rating	Unit
Ambient Temperature Range	T_A	- 40 to + 85	°C
Junction Temperature Range	T_J	- 40 to + 125	°C

■ Thermal Information

Parameter	Package	Die Attach	Symbol	Maximum	Unit
Thermal Resistance (Junction to Ambient)	SOT-23	Non-Conductive Epoxy	θ_{ja}	280	$^{\circ}\text{C} / \text{W}$
	SOT-25	Non-Conductive Epoxy		280	
	SOT-89	Conductive Epoxy		180	
		Non-Conductive Epoxy		180	
	TO-92	Conductive Epoxy		150	
		Non-Conductive Epoxy		150	
Thermal Resistance (Junction to Case)	SOT-23**	Non-Conductive Epoxy	θ_{jc}	140	$^{\circ}\text{C} / \text{W}$
	SOT-25**	Non-Conductive Epoxy		140	
	SOT-89*	Conductive Epoxy		46	
		Non-Conductive Epoxy		46	
	TO-92**	Conductive Epoxy		80	
		Non-Conductive Epoxy		80	
Internal Power Dissipation	SOT-23	Non-Conductive Epoxy	P_D	400	mW
	SOT-25	Non-Conductive Epoxy		400	
	SOT-89	Conductive Epoxy		550	
		Non-Conductive Epoxy		550	
	TO-92	Conductive Epoxy		625	
		Non-Conductive Epoxy		625	
Maximum Junction Temperature				150	$^{\circ}\text{C}$
Solder Iron (10 Sec)***				350	$^{\circ}\text{C}$

* Measure θ_{jc} on backside center of tab.

** Measure θ_{jc} on center of molding compound if IC has no tab.

*** MIL-STD-202G 210F

■ Electrical Specifications

TA = 25°C unless otherwise noted

Parameter	Symbol	Test Condition	Min	Typ	Max	Units	
Input Voltage	V_{IN}		Note 1		7	V	
Output Voltage Accuracy	V_O	$I_O=1mA$	-1.5		1.5	%	
Dropout Voltage	$V_{DROPOUT}$	$I_O=300mA$ $V_O=V_{O(NOM)}-2.0\%$	$1.3V \leq V_{O(NOM)} \leq 2.0V$		See chart	1300	mV
			$2.0V < V_{O(NOM)} \leq 2.8V$			400	
			$2.8V < V_{O(NOM)}$			300	
		$I_O=200mA$ $V_O=V_{O(NOM)}-2.0\%$	$1.3V \leq V_{O(NOM)} < 1.5V$		See chart	1200	
			$1.5V \leq V_{O(NOM)} < 1.8V$			1000	
			$1.8V \leq V_{O(NOM)} \leq 2.0V$			700	
Output Current	I_O	$V_O > 1.2V$	300			mA	
Current Limit	I_{LIM}	$V_O > 1.2V$	300	450		mA	
Short Circuit Current, Note2	I_{SC}	$V_O < 0.8V$		150	300	mA	
Quiescent Current	I_Q	$I_O=0mA$		30	50	μA	
Ground Pin Current	I_{GND}	$I_O=1mA$ to 300mA		35		μA	
Line Regulation	REG_{LINE}	$I_O=1mA$ $V_{IN}=V_O+1$ to V_O+2	$1.3V \leq V_O \leq 1.4V$	-0.2		0.2	%
			$1.4V < V_O \leq 2.0V$	-0.15		0.15	
			$2.0V < V_O < 4.0V$	-0.1	0.02	0.1	
			$4.0V \leq V_O$	-0.4	0.2	0.4	
Load Regulation	REG_{LOAD}	$I_O=1mA$ to 300mA	-1	0.2	1	%	
Over Temperature Shutdown	OTS			150		°C	
Over Temperature Hysterisis	OTH			30		°C	
V_O Temperature Coefficient	TC			30		ppm/°C	
Power Supply Rejection	PSRR	$I_O=100mA$ $C_O=2.2\mu F$	f=100Hz		60		dB
			f=1kHz		50		
			f=10kHz		20		
Output Voltage Noise	eN	f=10Hz to 100kHz $I_O=10mA$			30	μV_{rms}	

 Note1: $V_{IN(MIN)} = V_{OUT} + V_{DROPOUT}$

Note2: To prevent the Short Circuit Current protection feature from being prematurely activated, the input voltage must be applied before a current source load is applied.



■ Detailed Description

The AME8800/8811 family of CMOS regulators contain a PMOS pass transistor, voltage reference, error amplifier, over-current protection, and thermal shutdown.

The P-channel pass transistor receives data from the error amplifier, over-current shutdown, and thermal protection circuits. During normal operation, the error amplifier compares the output voltage to a precision reference. Over-current and Thermal shutdown circuits become active when the junction temperature exceeds 150°C, or the current exceeds 300mA. During thermal shutdown, the output voltage remains low. Normal operation is restored when the junction temperature drops below 120°C.

The AME8800/8811 switches from voltage mode to current mode when the load exceeds the rated output current. This prevents over-stress. The AME8800/8811 also incorporates current foldback to reduce power dissipation when the output is short circuited. This feature becomes active when the output drops below 0.8 volts, and reduces the current flow by 65%. Full current is restored when the voltage exceeds 0.8 volts.

■ External Capacitors

The AME8800/8811 is stable with an output capacitor to ground of 2.2 μ F or greater. Ceramic capacitors have the lowest ESR, and will offer the best AC performance. Conversely, Aluminum Electrolytic capacitors exhibit the highest ESR, resulting in the poorest AC response. Unfortunately, large value ceramic capacitors are comparatively expensive. One option is to parallel a 0.1 μ F ceramic capacitor with a 10 μ F Aluminum Electrolytic. The benefit is low ESR, high capacitance, and low overall cost.

A second capacitor is recommended between the input and ground to stabilize V_{IN} . The input capacitor should be at least 0.1 μ F to have a beneficial effect.

All capacitors should be placed in close proximity to the pins. A "Quiet" ground termination is desirable. This can be achieved with a "Star" connection.

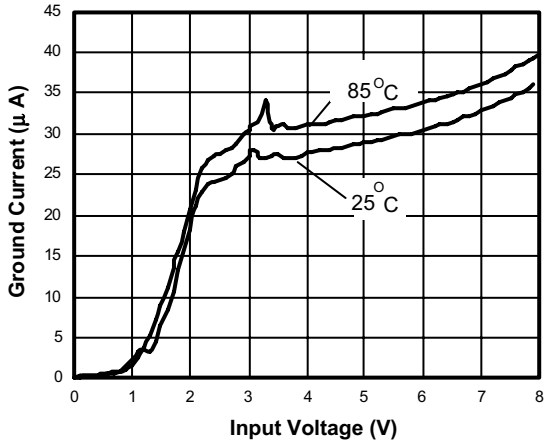
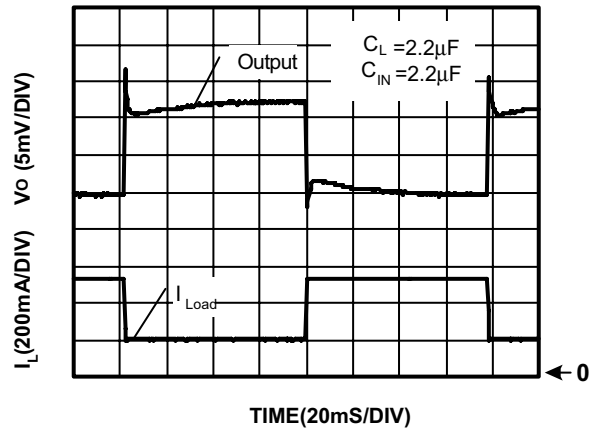
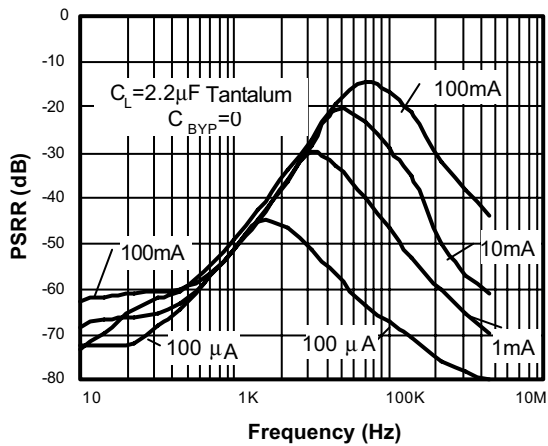
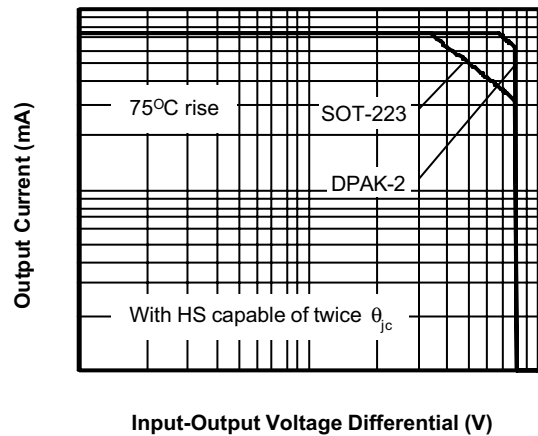
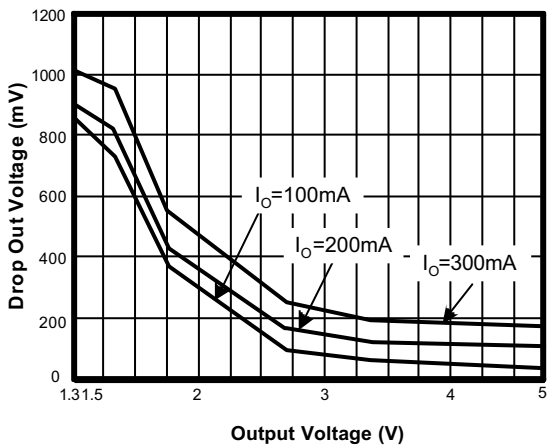
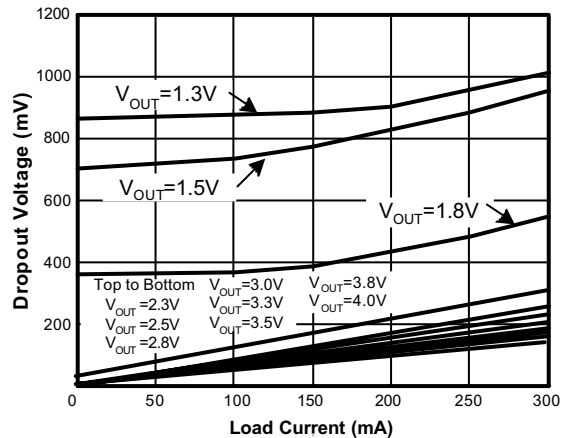
Ground Current vs. Input Voltage

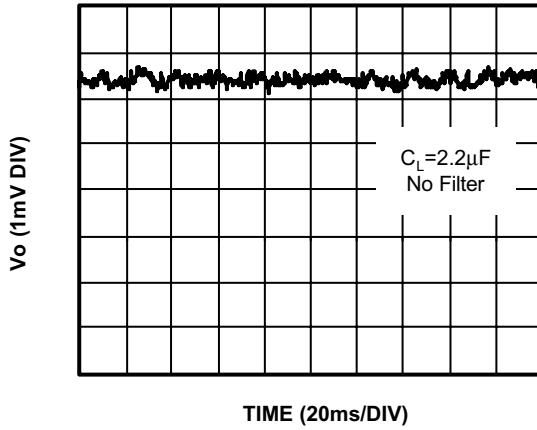
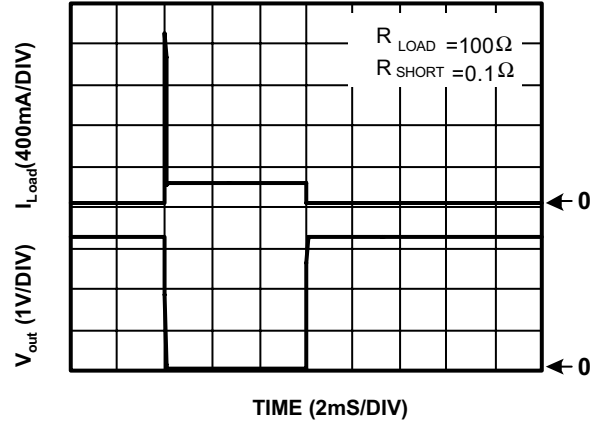
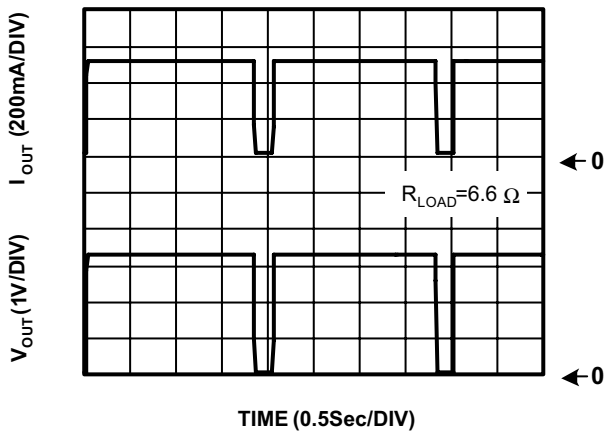
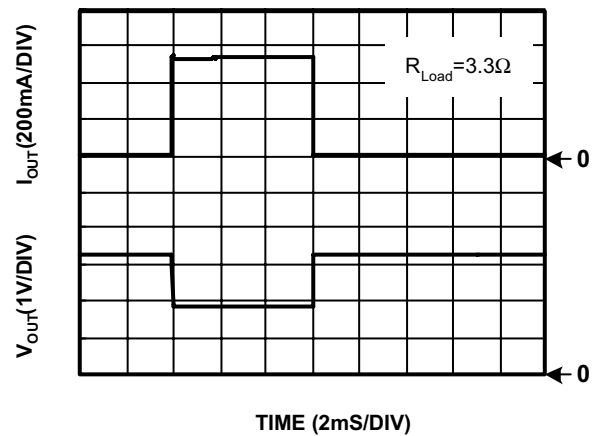
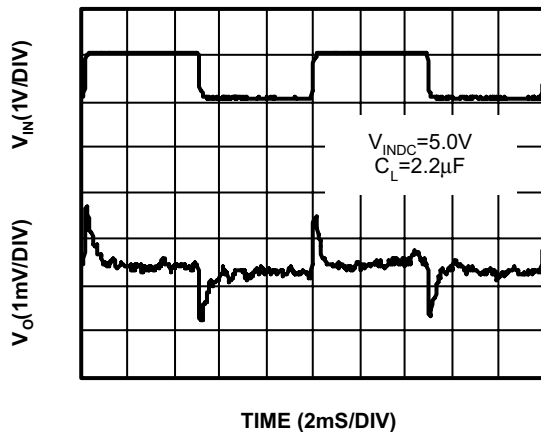
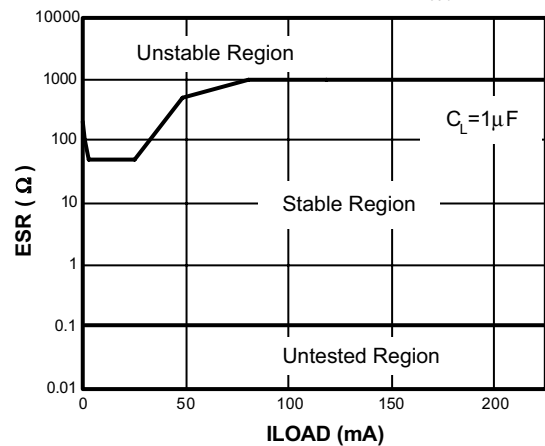
Load Step (1mA-300mA)

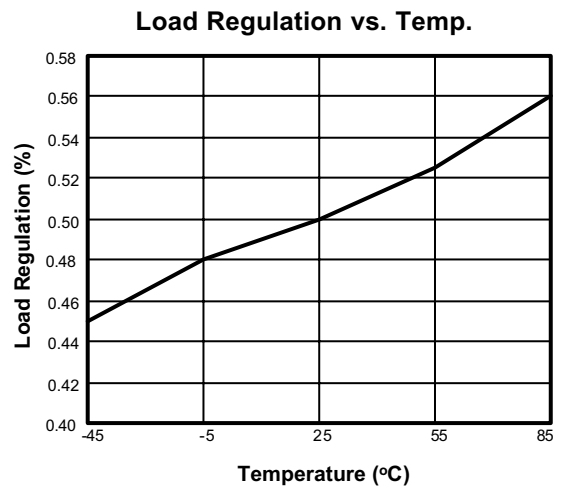
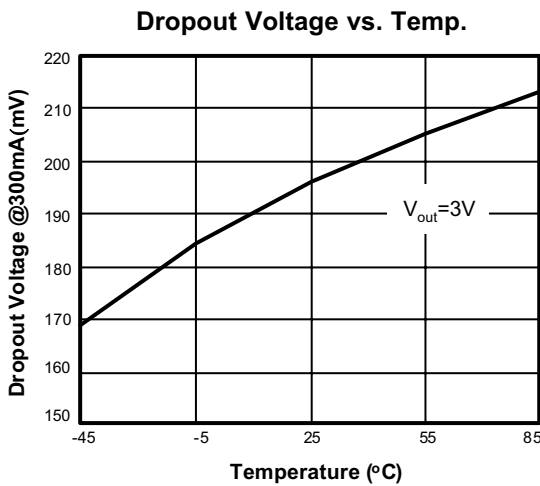
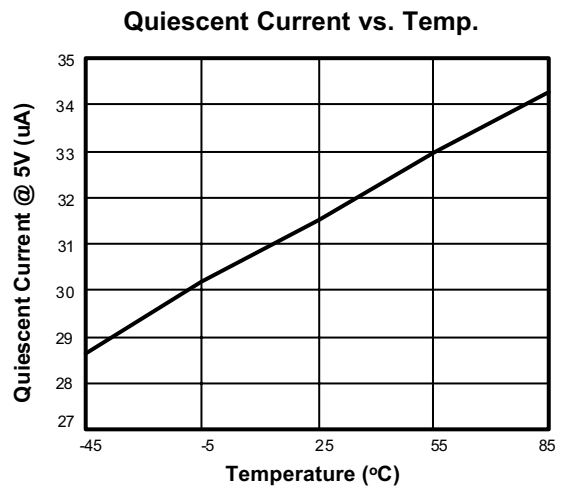
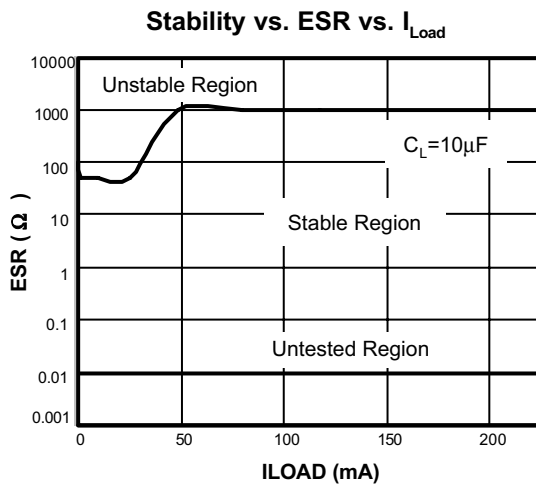
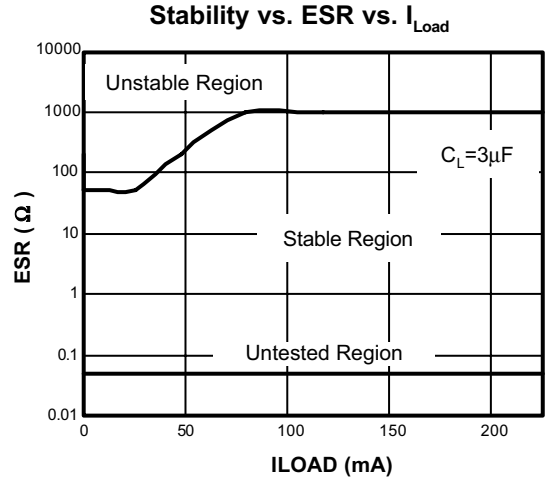
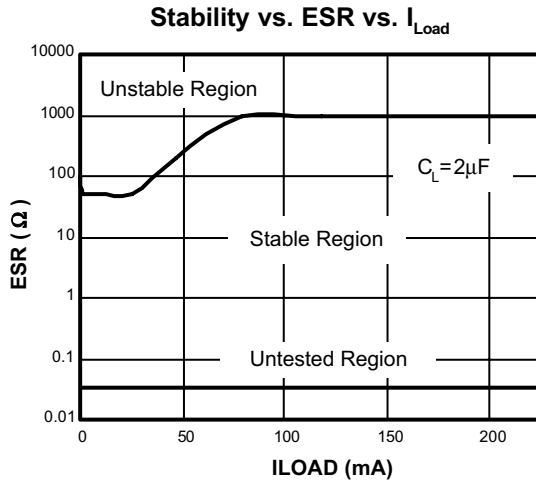
Power Supply Rejection Ratio

Safe Operating Area

Drop Out Voltage vs. Output Voltage

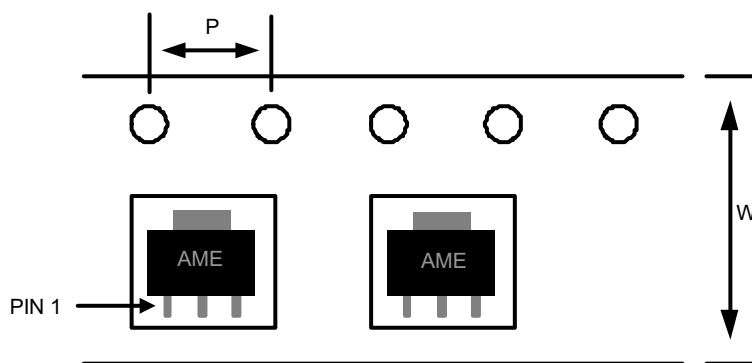
Drop Out Voltage vs. Load Current

Noise Measurement

Short Circuit Response

Overtemperature Shutdown

Current Limit Response

Line Transient Response

Stability vs. ESR vs. I_{Load}



■ Date Code Rule

Marking			Date Code		Year
A	A	A	W	W	xxx0
A	A	A	W	<u>W</u>	xxx1
A	A	A	<u>W</u>	W	xxx2
A	A	A	<u>W</u>	<u>W</u>	xxx3
A	A	<u>A</u>	W	W	xxx4
A	A	<u>A</u>	W	<u>W</u>	xxx5
A	A	<u>A</u>	<u>W</u>	W	xxx6
A	A	<u>A</u>	<u>W</u>	<u>W</u>	xxx7
A	<u>A</u>	A	W	W	xxx8
A	<u>A</u>	A	W	<u>W</u>	xxx9

■ Tape and Reel Dimension
SOT-89

Carrier Tape, Number of Components Per Reel and Reel Size

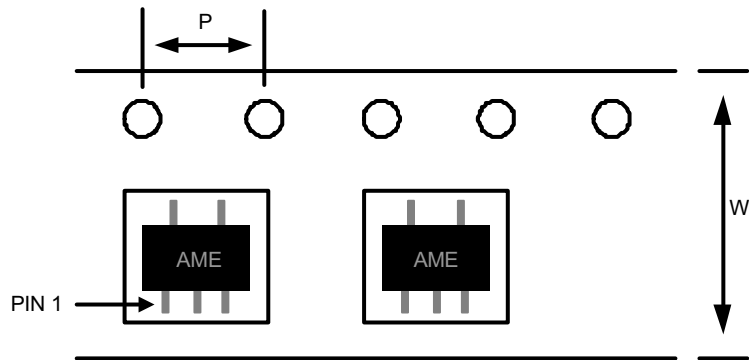
Package	Carrier Width (W)	Pitch (P)	Part Per Full Reel	Reel Size
SOT-89	12.0±0.1 mm	4.0±0.1 mm	1000pcs	180±1 mm

■ Tape and Reel Dimension
SOT-25

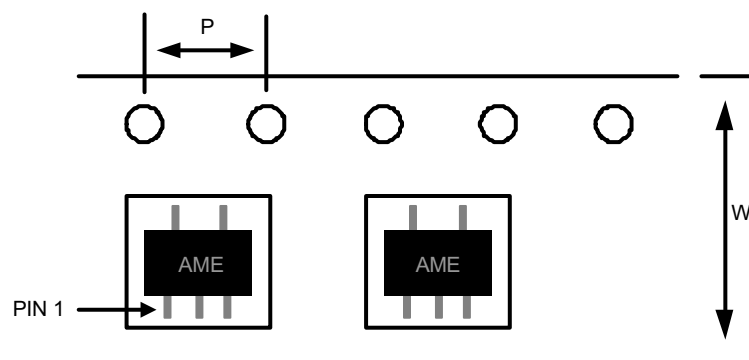
Carrier Tape, Number of Components Per Reel and Reel Size

Package	Carrier Width (W)	Pitch (P)	Part Per Full Reel	Reel Size
SOT-25	8.0±0.1 mm	4.0±0.1 mm	3000pcs	180±1 mm

TSOT-25

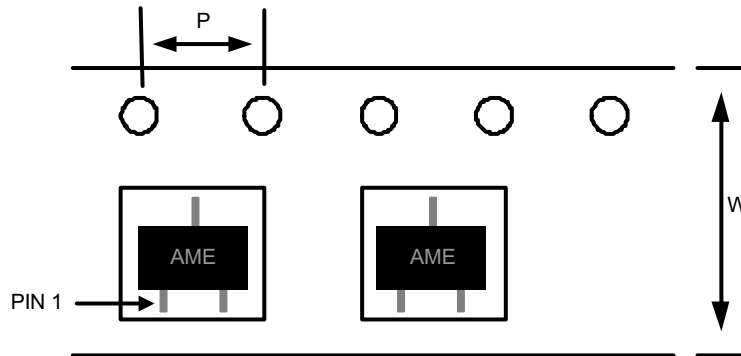
Carrier Tape, Number of Components Per Reel and Reel Size

Package	Carrier Width (W)	Pitch (P)	Part Per Full Reel	Reel Size
TSOT-25	8.0±0.1 mm	4.0±0.1 mm	3000pcs	180±1 mm

■ Tape and Reel Dimension
SOT-23

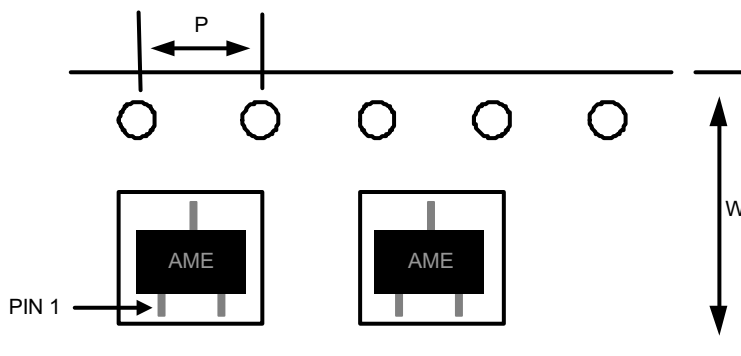
Carrier Tape, Number of Components Per Reel and Reel Size

Package	Carrier Width (W)	Pitch (P)	Part Per Full Reel	Reel Size
SOT-23	8.0±0.1 mm	4.0±0.1 mm	3000pcs	180±1 mm

SOT-23 (Low Profile)

Carrier Tape, Number of Components Per Reel and Reel Size

Package	Carrier Width (W)	Pitch (P)	Part Per Full Reel	Reel Size
SOT-23 (Low Profile)	8.0±0.1 mm	4.0±0.1 mm	3000pcs	180±1 mm

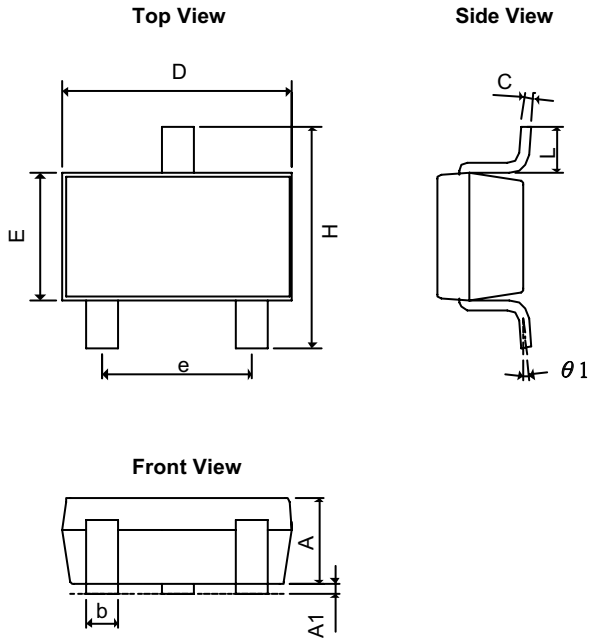

■ Package Dimension

SOT-23



SYMBOLS	MILLIMETERS		INCHES	
	MIN	MAX	MIN	MAX
A	1.00	1.40	0.0394	0.0551
A ₁	0.00	0.15	0.0000	0.0059
b	0.35	0.50	0.0138	0.0197
C	0.09	0.25	0.0035	0.0098
D	2.70	3.10	0.1063	0.1220
E	1.40	1.80	0.0551	0.0709
e	1.90 BSC		0.0748 BSC	
H	2.40	3.00	0.09449	0.11811
L	0.35BSC		0.0138BSC	
θ1	0°	10°	0°	10°

SOT-23-L

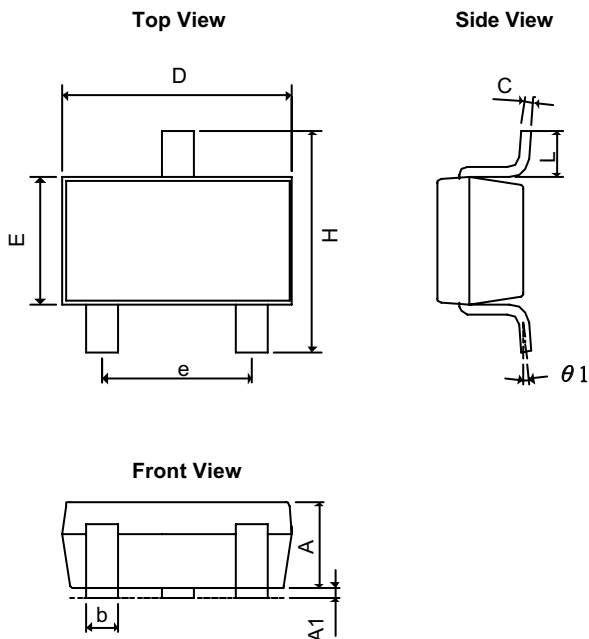

SYMBOLS	MILLIMETERS		INCHES	
	MIN	MAX	MIN	MAX
A+A ₁	0.80	1.30	0.0315	0.0512
b	0.35	0.50	0.0138	0.0197
C	0.08	0.25	0.0031	0.0098
D	2.70	3.10	0.1063	0.1220
E	1.20	1.80	0.0472	0.0709
e	1.90 BSC		0.0748 BSC	
H	2.40	3.00	0.09449	0.11811
L	0.35BSC		0.0138BSC	
θ1	0°	10°	0°	10°

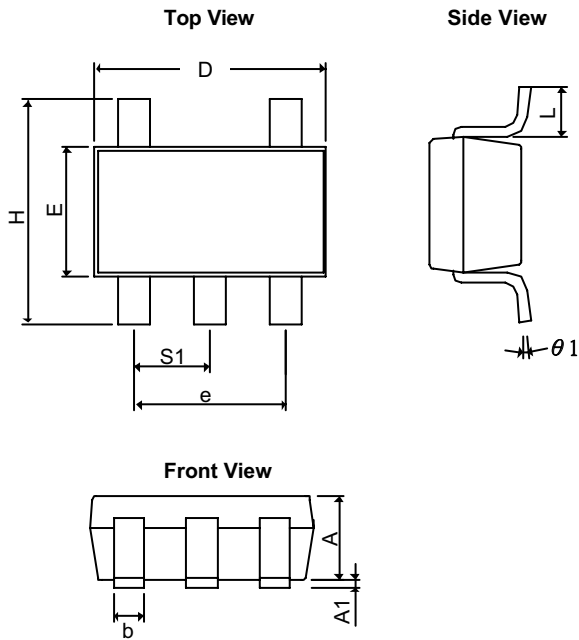
■ Package Dimension
SOT-25

SYMBOLS	MILLIMETERS		INCHES	
	MIN	MAX	MIN	MAX
A	1.20REF		0.0472REF	
A₁	0.00	0.15	0.0000	0.0059
b	0.30	0.55	0.0118	0.0217
D	2.70	3.10	0.1063	0.1220
E	1.40	1.80	0.0551	0.0709
e	1.90 BSC		0.07480 BSC	
H	2.60	3.00	0.10236	0.11811
L	0.37BSC		0.0146BSC	
θ_1	0°	10°	0°	10°
S₁	0.95BSC		0.0374BSC	

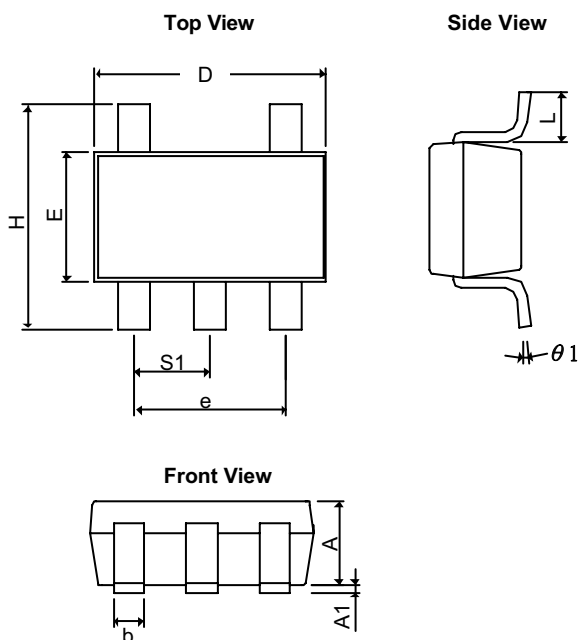
TSOT-25

SYMBOLS	MILLIMETERS		INCHES	
	MIN	MAX	MIN	MAX
A+A₁	0.90	1.25	0.0354	0.0492
b	0.30	0.50	0.0118	0.0197
D	2.70	3.10	0.1063	0.1220
E	1.40	1.80	0.0551	0.0709
e	1.90 BSC		0.07480 BSC	
H	2.40	3.00	0.09449	0.11811
L	0.35BSC		0.0138BSC	
θ_1	0°	10°	0°	10°
S₁	0.95BSC		0.0374BSC	

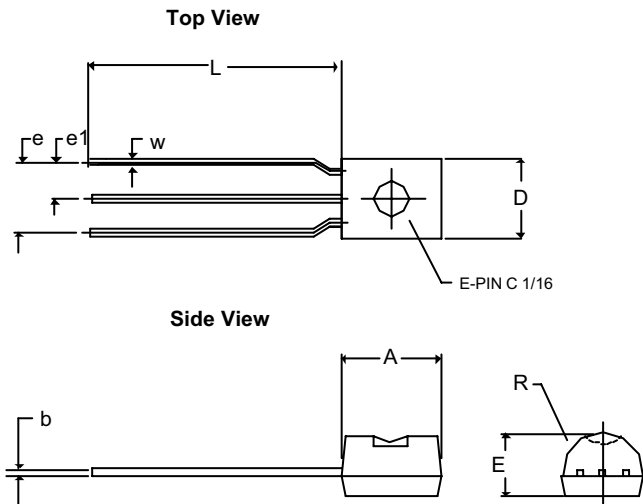
■ Package Dimension
TO-92-3 (tape pack)

SYMBOLS	MILLIMETERS		INCHES	
	MIN	MAX	MIN	MAX
A	2.80	4.95	0.1102	0.1949
b	0.40REF		0.0157REF	
E	2.40	3.94	0.0945	0.1551
e	5.08REF		0.2REF	
e1	2.54REF		0.1REF	
L	12.70	15.49	0.5000	0.6098
R	2.00		0.0787	
W	0.35	0.76	0.0138	0.0299
D	3.80	4.95	0.1496	0.1949

Notes:

1. Package outline exclusive of any mold flashes.
2. Package outline exclusive of burr dimension.
3. Lead pitch=2.54mm is bulk pack.
4. Lead pitch=5.08mm is tape pack.

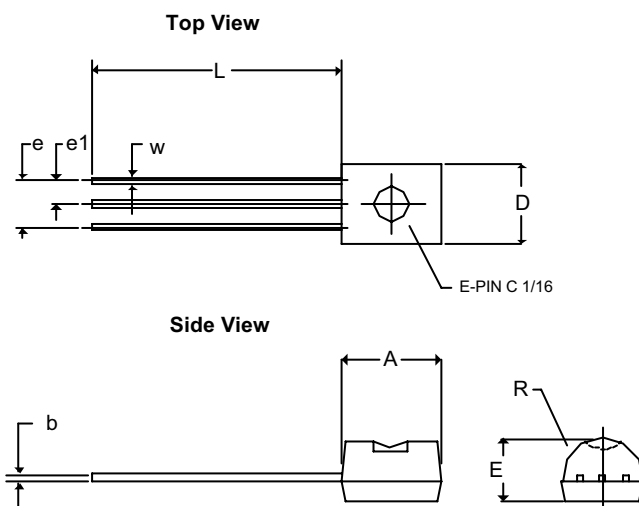
TO-92-3 (bulk pack)

SYMBOLS	MILLIMETERS		INCHES	
	MIN	MAX	MIN	MAX
A	2.80	4.95	0.1102	0.1949
b	0.40REF		0.0157REF	
E	3.94REF		0.1551REF	
e	2.54REF		0.1000REF	
e1	1.27REF		0.0500REF	
L	12.70	15.49	0.5000	0.6098
R	2.29		0.0902	
W	0.35	0.76	0.0138	0.0299
D	3.80	4.95	0.1496	0.1949

Notes:

1. Package outline exclusive of any mold flashes dimension.
2. Package outline exclusive of burr dimension.
3. Lead pitch=2.54mm is bulk pack.
4. Lead pitch=5.08mm is tape pack.

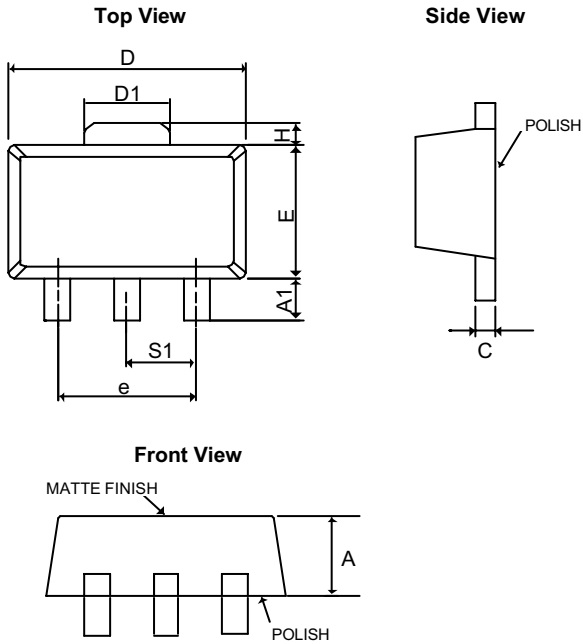
■ Package Dimension
SOT-89

SYMBOLS	MILLIMETERS		INCHES	
	MIN	MAX	MIN	MAX
A	1.39	1.60	0.05472	0.06299
A₁	0.8REF		0.0315REF	
C	0.35	0.44	0.01378	0.01732
D	4.39	4.60	0.17283	0.1811
D₁	1.35	1.83	0.05315	0.07205
E	2.28	3.60	0.08976	0.14173
e	3.00REF		0.1181REF	
H	0.70REF		0.0276REF	
S₁	1.50REF		0.0590REF	



www.ame.com.tw
E-Mail: sales@ame.com.tw

Life Support Policy:

These products of AME, Inc. are not authorized for use as critical components in life-support devices or systems, without the express written approval of the president of AME, Inc.

AME, Inc. reserves the right to make changes in the circuitry and specifications of its devices and advises its customers to obtain the latest version of relevant information.

©AME, Inc. , March 2006

Document: 2006/2095-DS8800/8811-T.01

Corporate Headquarter

AME, Inc.

2F, 302 Rui-Guang Road, Nei-Hu District

Taipei 114, Taiwan.

Tel: 886 2 2627-8687

Fax: 886 2 2659-2989

U.S.A.(Subsidiary)

Analog Microelectronics, Inc.

3100 De La Cruz Blvd., Suite 201

Santa Clara, CA. 95054-2046

Tel : (408) 988-2388

Fax: (408) 988-2489