



■ Pin Configuration



AME 8845AECSxxx

1. V_{IN}
2. GND (heat sink)
3. V_{OUT}



AME 8845BECSxxx

1. GND
2. V_{OUT} (heat sink)
3. V_{IN}



AME8845AEGTxxx

1. V_{IN}
2. GND
3. V_{OUT}



AME8845BEGTxxx

1. GND
2. V_{OUT}
3. V_{IN}

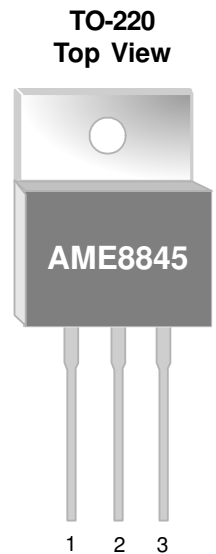

AME 8845AEBTxxx

1. V_{IN}
2. GND (heat sink)
3. V_{OUT}

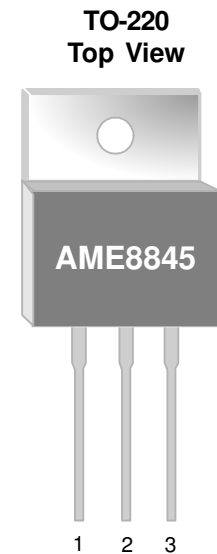

AME 8845BEBTxxx

1. GND
2. V_{OUT} (heat sink)
3. V_{IN}



■ Pin Configuration

TO-263-3L
Top View

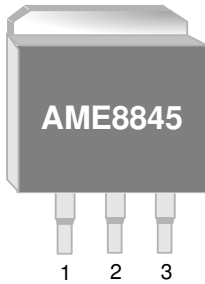

AME 8845AEDTxxx

- 1. V_{IN}
- 2. GND (heat sink)
- 3. V_{OUT}

TO-263-3L
Top View

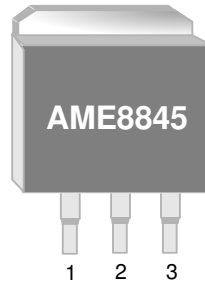

AME 8845BEDTxxx

- 1. GND (heat sink)
- 2. V_{OUT}
- 3. V_{IN}

TO-263-5L
Top View

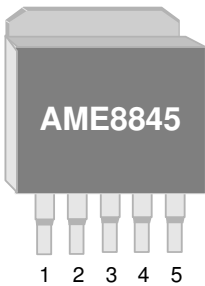

AME 8845AEDVxxx

- 1. V_{IN}
- 2. EN
- 3. GND (heat sink)
- 4. SENSE
- 5. V_{OUT}

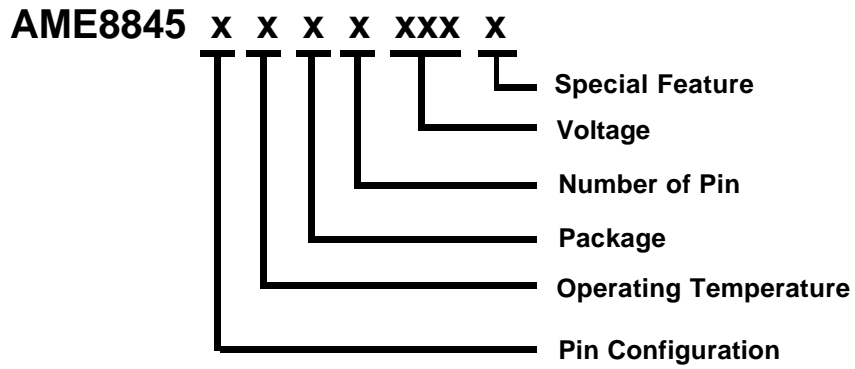
■ Ordering Information

Pin Configuration	Operating Temperature Range	Package Type	Number of Pins	Voltage	Special Feature
A: 1. VIN (TO-252) 2. GND 3. VOUT B: 1. GND 2. VOUT 3. VIN	E: -40°C to 85°C	B: TO-220 C: TO-252 D: TO-263 G: SOT-223	S: 2 T: 3 V: 5	150: V=1.5V 180: V=1.8V 250: V=2.5V 330: V=3.3V	Z: Lead Free
A: 1. VIN (TO-263-3) 2. GND 3. VOUT B: 1. GND 2. VOUT 3. VIN					
A: 1. VIN (TO-263-5) 2. EN 3. GND 4. SENSE 5. VOUT					
A: 1. VIN (TO-220) 2. GND 3. VOUT B: 1. GND 2. VOUT 3. VIN					
A: 1. VIN (SOT-223) 2. GND 3. VOUT B: 1. VIN (SOT-223) 2. GND 3. VOUT					

■ Ordering Information

Part Number	Marking*	Output Voltage	Package	Operating Temp. Range
AME8845AEBT150	AME8845 AEBT150 yyww	1.50	TO-220	- 40°C to + 85°C
AME8845AEBT150Z	AME8845 AEBT150 yyww	1.50	TO-220	- 40°C to + 85°C
AME8845BEBT150	AME8845 BEBT150 yyww	1.50	TO-220	- 40°C to + 85°C
AME8845BEBT150Z	AME8845 BEBT150 yyww	1.50	TO-220	- 40°C to + 85°C
AME8845AEDT150	AME8845 AEDT150 yyww	1.50	TO-263-3	- 40°C to + 85°C
AME8845AEDT150Z	AME8845 AEDT150 yyww	1.50	TO-263-3	- 40°C to + 85°C
AME8845BEDT150	AME8845 BEDT150 yyww	1.50	TO-263-3	- 40°C to + 85°C
AME8845BEDT150Z	AME8845 BEDT150 yyww	1.50	TO-263-3	- 40°C to + 85°C
AME8845AEDV150	AME8845 AEDV150 yyww	1.50	TO-263-5	- 40°C to + 85°C
AME8845AEDV150Z	AME8845 AEDV150 yyww	1.50	TO-263-5	- 40°C to + 85°C
AME8845AEBT180	AME8845 AEBT180 yyww	1.80	TO-220	- 40°C to + 85°C
AME8845AEBT180Z	AME8845 AEBT180 yyww	1.80	TO-220	- 40°C to + 85°C
AME8845BEBT180	AME8845 BEBT180 yyww	1.80	TO-220	- 40°C to + 85°C

Note: yyww/ yww represents the date code

* A line on top of the first letter represents lead free plating such as $\bar{\text{A}}$ ME8845

Please consult AME sales office or authorized Rep./Distributor for output voltage and package type availability.



■ Ordering Information

Part Number	Marking*	Output Voltage	Package	Operating Temp. Range
AME8845BEBT180Z	AME8845 BEBT180 yyww	1.80	TO-220	- 40°C to + 85°C
AME8845AEDT180	AME8845 AEDT180 yyww	1.80	TO-263-3	- 40°C to + 85°C
AME8845AEDT180Z	AME8845 AEDT180 yyww	1.80	TO-263-3	- 40°C to + 85°C
AME8845BEDT180	AME8845 BEDT180 yyww	1.80	TO-263-3	- 40°C to + 85°C
AME8845BEDT180Z	AME8845 BEDT180 yyww	1.80	TO-263-3	- 40°C to + 85°C
AME8845AEDV180	AME8845 AEDV180 yyww	1.80	TO-263-5	- 40°C to + 85°C
AME8845AEDV180Z	AME8845 AEDV180 yyww	1.80	TO-263-5	- 40°C to + 85°C
AME8845AEGT180	BAZyww	1.80	SOT-223	- 40°C to + 85°C
AME8845AEGT180Z	BAZyww	1.80	SOT-223	- 40°C to + 85°C
AME8845AEBT250	AME8845 AEBT250 yyww	2.50	TO-220	- 40°C to + 85°C
AME8845AEBT250Z	AME8845 AEBT250 yyww	2.50	TO-220	- 40°C to + 85°C
AME8845BEBT250	AME8845 BEBT250 yyww	2.50	TO-220	- 40°C to + 85°C
AME8845BEBT250Z	AME8845 BEBT250 yyww	2.50	TO-220	- 40°C to + 85°C
AME8845AEDT250	AME8845 AEDT250 yyww	2.50	TO-263-3	- 40°C to + 85°C
AME8845AEDT250Z	AME8845 AEDT250 yyww	2.50	TO-263-3	- 40°C to + 85°C

■ Ordering Information

Part Number	Marking*	Output Voltage	Package	Operating Temp. Range
AME8845BEDT250	AME8845 BEDT250 yyww	2.50	TO-263-3	- 40°C to + 85°C
AME8845BEDT250Z	AME8845 BEDT250 yyww	2.50	TO-263-3	- 40°C to + 85°C
AME8845AEDV250	AME8845 AEDV250 yyww	2.50	TO-263-5	- 40°C to + 85°C
AME8845AEDV250Z	AME8845 AEDV250 yyww	2.50	TO-263-5	- 40°C to + 85°C
AME8845AEGT250	AZSyww	2.50	SOT-223	- 40°C to + 85°C
AME8845AEGT250Z	AZSyww	2.50	SOT-223	- 40°C to + 85°C
AME8845AEBT330	AME8845 AEBT330 yyww	3.30	TO-220	- 40°C to + 85°C
AME8845AEBT330Z	AME8845 AEBT330 yyww	3.30	TO-220	- 40°C to + 85°C
AME8845BEBT330	AME8845 BEBT330 yyww	3.30	TO-220	- 40°C to + 85°C
AME8845BEBT330Z	AME8845 BEBT330 yyww	3.30	TO-220	- 40°C to + 85°C
AME8845AEDT330	AME8845 AEDT330 yyww	3.30	TO-263-3	- 40°C to + 85°C
AME8845AEDT330Z	AME8845 AEDT330 yyww	3.30	TO-263-3	- 40°C to + 85°C
AME8845BEDT330	AME8845 BEDT330 yyww	3.30	TO-263-3	- 40°C to + 85°C
AME8845BEDT330Z	AME8845 BEDT150 yyww	3.30	TO-263-3	- 40°C to + 85°C
AME8845AEDV330Z	AME8845 AEDV330 yyww	3.30	TO-263-5	- 40°C to + 85°C
AME8845AEDV330Z	AME8845 AEDV330 yyww	3.30	TO-263-5	- 40°C to + 85°C



■ Absolute Maximum Ratings

Parameter	Maximum	Unit
Input Voltage	7	V
Output Current	$P_D / (V_{IN} - V_O)$	mA
Output Voltage	GND - 0.3 to $V_{IN} + 0.3$	V
ESD Classification	B	

Caution: Stress above the listed absolute maximum rating may cause permanent damage to the device

■ Recommended Operating Conditions

Parameter	Rating	Unit
Ambient Temperature Range	- 40 to + 85	°C
Junction Temperature	- 40 to + 125	°C

■ Thermal Information

Parameter		Maximum		Unit
Thermal Resistance (θ_{ja})	TO-252	90		°C / W
	TO-263	60		
	TO-220	50		
	SOT-223	160		
Thermal Resistance (θ_{jc})	TO-252	Conductive	7	°C / W
		Non-Conductive	30	
	TO-263	Conductive	7	
		Non-Conductive	27	
	TO-220	Conductive	7	
		Non-Conductive	24	
	SOT-223	Conductive	7	
		Non-Conductive	31	
Internal Power Dissipation (P_D) ($\Delta T = 100^\circ\text{C}$)	TO-252	1200		mW
	TO-263	2800		
	TO-220	3000		
	SOT-223	625		
Maximum Junction Temperature		150		°C
Maximum Lead Temperature (10 Sec)		300		°C

■ Electrical Specifications

$V_{IN} = V_{O(Nom)} + 1V$, $C_{IN}=0.1\mu F$, $C_{OUT}=2.2\mu F$, $T_A = 25^\circ C$ unless otherwise noted

Parameter	Symbol	Test Condition	Min	Typ	Max	Units
Input Voltage	V_{IN}		Note 1		6	V
Output Voltage Accuracy	V_O	$I_O=1mA$	-1.5		1.5	%
Dropout Voltage	$V_{DROPOUT}$	$I_O=3A$ $V_O=V_{O(NOM)} - 2.0\%$	$1.5V \leq V_{O(NOM)} \leq 1.8V$		1200	mV
			$1.8V < V_{O(NOM)} < 2.5V$		700	
			$2.5V \leq V_{O(NOM)}$		300	
Output Current	I_O	$V_O > 1.2V$		3000		mA
Current Limit	I_{LIM}	$V_O > 1.2V$		3		A
Short Circuit Current	I_{SC}	$V_{IN} = V_{O(NOM)} + 1V$, $V_O < 0.4V$		1.7		A
Quiescent Current	I_Q	$I_O = 0mA$		300	400	μA
Ground Pin Current	I_{GND}	$I_O = 1mA$ to 3A		300		μA
Line Regulation	REG_{LINE}	$I_O = 1mA$, $V_{IN} = V_O + 1$ to $V_O + 2$	-0.2	0.1	0.2	%
Load Regulation	REG_{LOAD}	$I_O = 1mA$ to 3A	-1		1	%
Over Temperature Shutdown	OTS			140		$^\circ C$
Over Temperature Hysteresis	OTH			30		$^\circ C$
V_O Temperature Coefficient	TC			30		ppm/ $^\circ C$
Power Supply Rejection	PSRR	$I_O = 100mA$ $C_O = 10\mu F$	$f = 100Hz$		70	dB
			$f = 1kHz$		50	
Output Voltage Noise	eN	$f = 10Hz$ to 100kHz $I_O = 10mA$			30	μV_{rms}
EN Input Threshold	V_{EH}	$V_{IN} = V_{IN,MIN}$ to $V_{IN,MAX}$	$V_{IN} * 0.8$		V_{IN}	V
	V_{EL}		0		0.4	
EN Input Leakage	I_{EH}	$V_{EN} = V_{IN} = 5V$			2	μA
	I_{EL}	$V_{EN} = 0V$, $V_{IN} = 5V$			2	
Shutdown Current	I_{SD}	$V_{EN} = 0V$, $V_{IN} = 5V$			10	μA

Note1: $V_{IN(min)} = V_{OUT} + V_{DROPOUT}$

■ Detailed Description

The AME8845 family of CMOS regulators contain a PMOS pass transistor, voltage reference, error amplifier, over-current protection, and thermal shutdown.

The P-channel pass transistor receives data from the error amplifier, over-current shutdown, and thermal protection circuits. During normal operation, the error amplifier compares the output voltage to a precision reference. Over-current and Thermal shutdown circuits become active when the junction temperature exceeds 140°C, or the current exceeds 4.5A. During thermal shutdown, the output voltage remains low. Normal operation is restored when the junction temperature drops below 110°C.

The AME8845 behaves like a current source when the load reaches 4.5A. However, if the load impedance drops below 0.3 ohms, the current drops back to 600mA to prevent excessive power dissipation. Normal operation is restored when the load resistance exceeds 0.75 ohms.

■ External Capacitors

The AME8845 is stable with an output capacitor to ground of 2.2 μ F or greater. Ceramic capacitors have the lowest ESR, and will offer the best AC performance. Conversely, Aluminum Electrolytic capacitors exhibit the highest ESR, resulting in the poorest AC response. Unfortunately, large value ceramic capacitors are comparatively expensive. One option is to parallel a 0.1 μ F ceramic capacitor with a 10 μ F Aluminum Electrolytic. The benefit is low ESR, high capacitance, and low overall cost.

A second capacitor is recommended between the input and ground to stabilize V_{in} . The input capacitor should be at least 0.1 μ F to have a beneficial effect.

All capacitors should be placed in close proximity to the pins. A "Quiet" ground termination is desirable. This can be achieved with a "Star" connection.



Temperature Stability

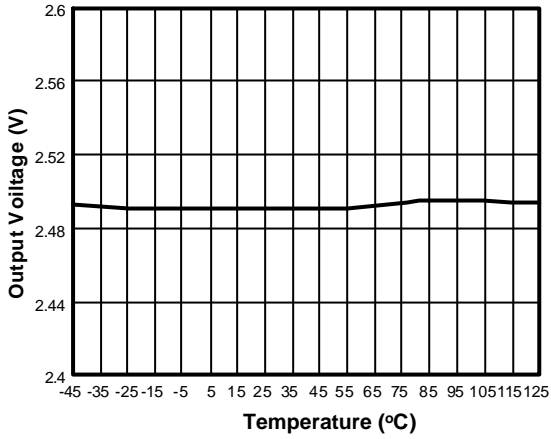

Dropout Voltage vs. Load Current

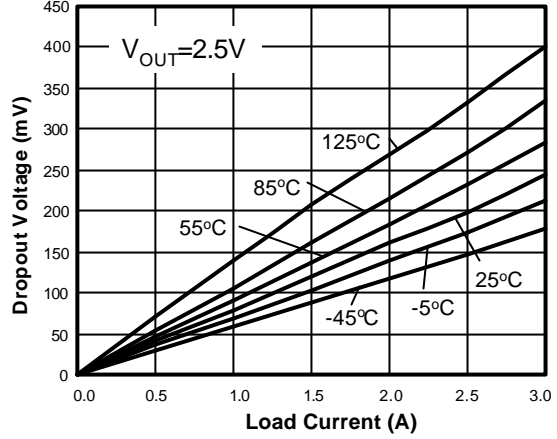

Quiescent Current vs. Temperature

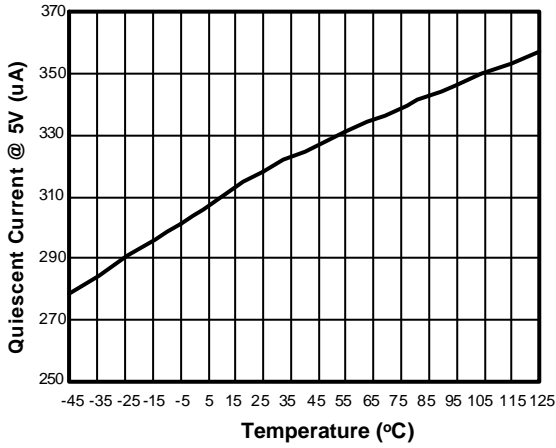

Dropout Voltage vs. Temperature

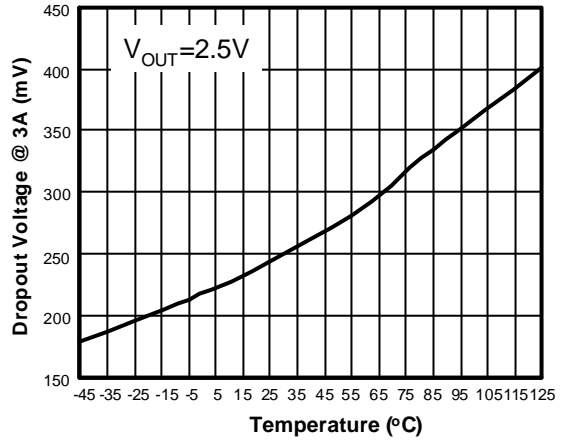

Quiescent Current vs. Supply Voltage

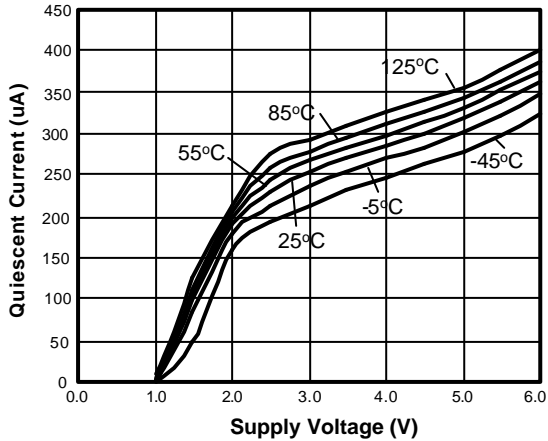

Current Limit vs. Temperature

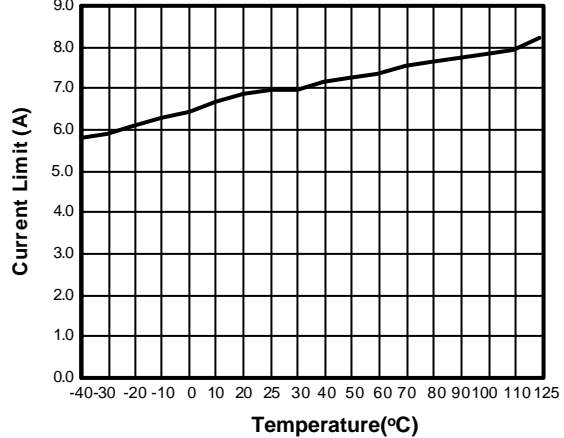



Output Voltage(2.5V) vs. Input Voltage

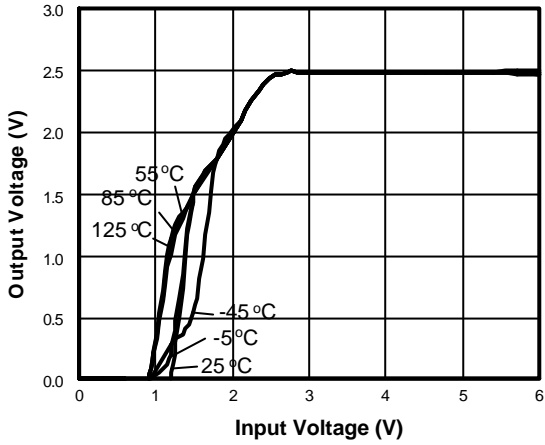

Output Noise vs. Frequency

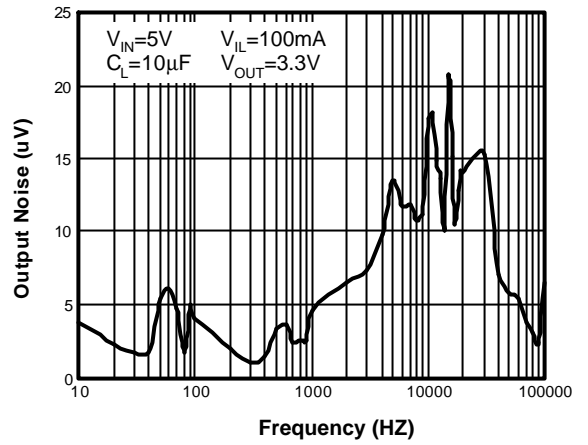

PSRR vs. Frequency

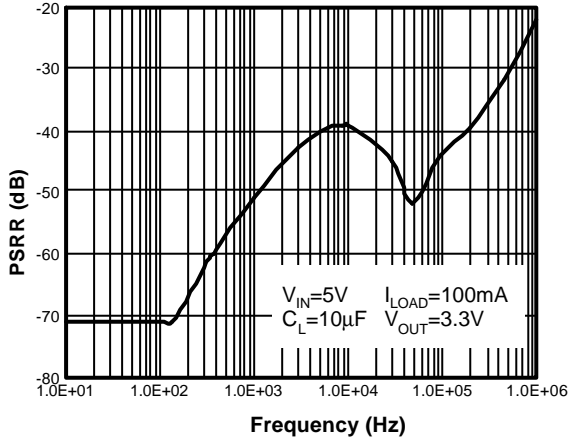

Ground Current vs. Load Current

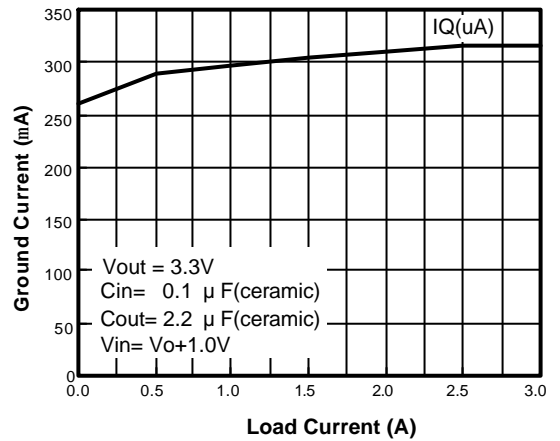

Load Regulation Deviation

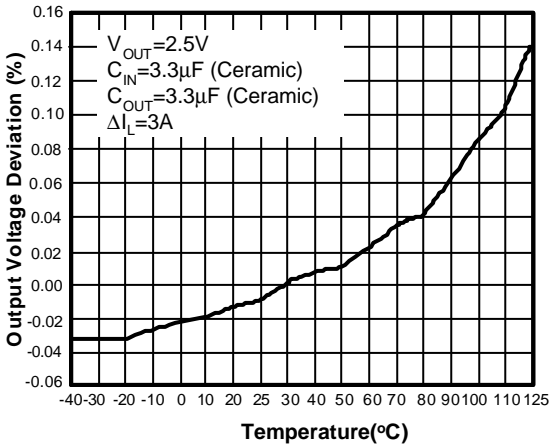

EN Pin Shutdown Response

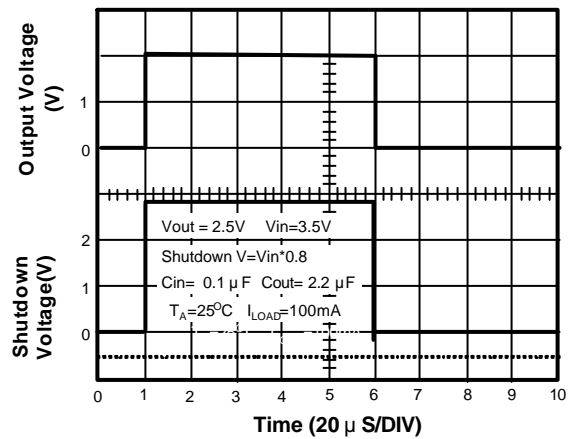



Line Transient Response

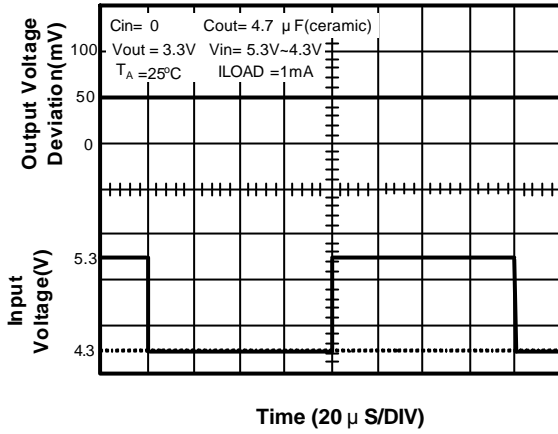

Load Transient Response

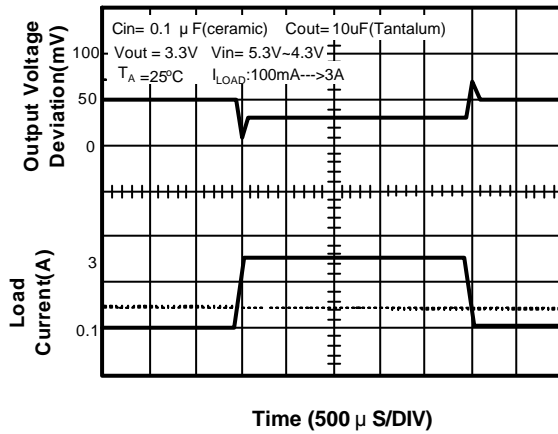



■ Package Dimension

TO-263-3

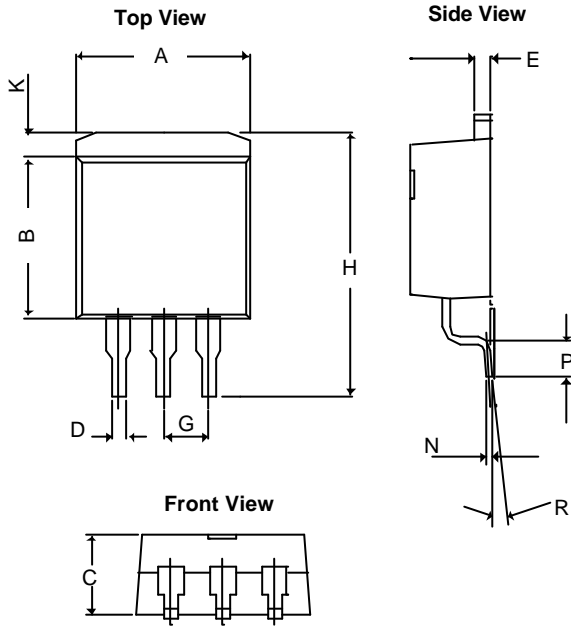

SYMBOLS	MILLIMETERS		INCHES	
	MIN	MAX	MIN	MAX
A	9.65	10.42	0.380	0.410
B	8.28	9.66	0.326	0.380
C	4.06	4.83	0.160	0.190
D	0.50	1.02	0.020	0.040
E	1.14	1.40	0.045	0.055
G	*2.54		*0.100	
H	14.60	15.60	0.5748	0.61417
K	0.99	2.93	0.03898	0.11535
N	0.381REF		0.015REF	
P	2.28	2.80	0.08976	0.11024
R	0°	8°	0°	8°

TO-263-5

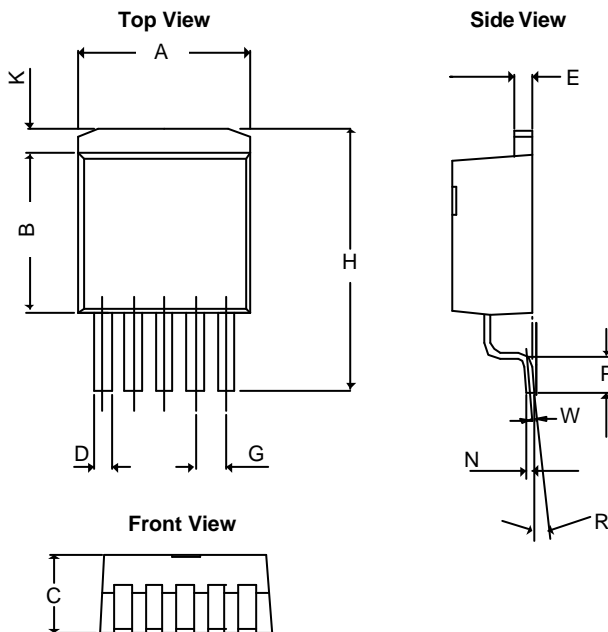

SYMBOLS	MILLIMETERS		INCHES	
	MIN	MAX	MIN	MAX
A	10.050	10.668	0.396	0.420
B	8.280	9.169	0.326	0.361
C	4.310	4.597	0.170	0.181
D	0.660	0.910	0.026	0.036
E	1.140	1.400	0.045	0.055
G	1.70REF		0.067 REF	
H	14.605	15.875	0.575	0.625
K	1.143	1.680	0.045	0.066
L	0.000	0.305	0.000	0.012
N	0.330	0.580	0.013	0.023
P	2.280	2.800	0.090	0.110
R	0°	8°	0°	8°
W	0.25REF		0.01REF	

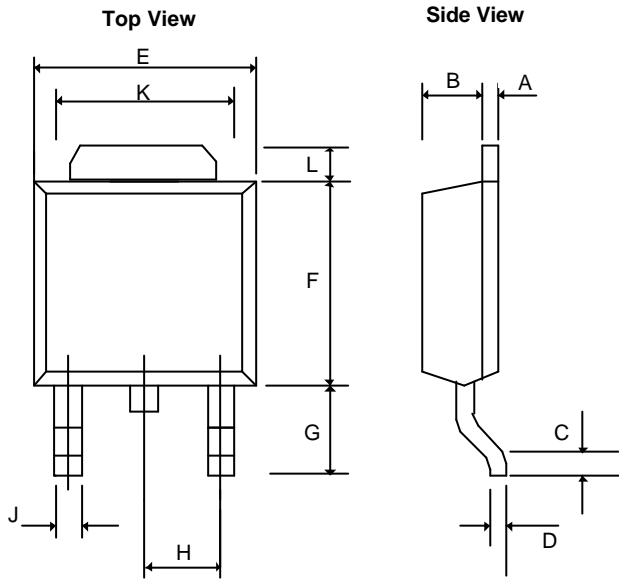
■ Package Dimension
TO-252(DPAK)-EIAJ

SYMBOLS	MILLIMETERS		INCHES	
	MIN	MAX	MIN	MAX
A	0.45	0.58	0.0177	0.0230
B	1.60	1.95	0.0630	0.0768
C	0.51	1.50	0.0201	0.0591
D	0.45	0.60	0.0177	0.0236
E	6.40	6.80	0.2520	0.2677
F	5.40	7.20	0.2126	0.2835
G	2.20	2.85	0.0866	0.1122
H	-	* 2.30	-	* 0.0906
J	-	0.97	-	0.0380
K	5.20	5.50	0.2047	0.2165
L	1.40REF		0.055REF	

*: Typical Value

Notes:

1. Controlling dimension: Millimeters.
2. Maximum lead thickness includes lead finish thickness. Minimum lead thickness is the minimum thickness of base material.

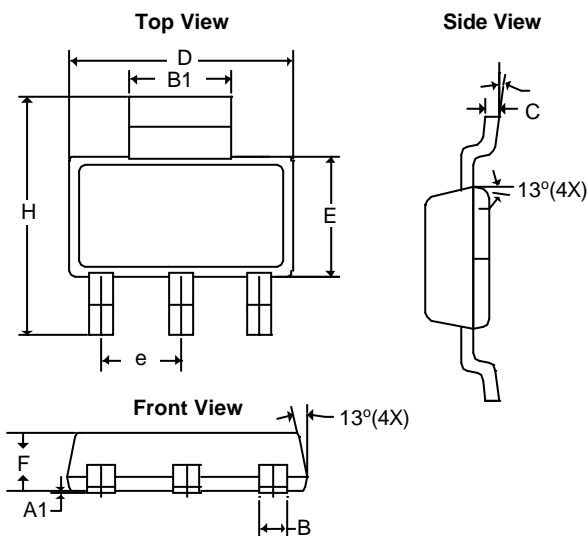
SOT-223

SYMBOLS	MILLIMETERS		INCHES	
	MIN	MAX	MIN	MAX
A ₁	0.02	0.10	0.0008	0.0039
B	0.60	0.84	0.0236	0.0330
B ₁	2.90	3.15	0.1140	0.1240
C	0.24	0.38	0.0094	0.0150
D	6.30	6.71	0.2480	0.2640
E	3.30	3.71	0.1299	0.1460
e	2.30 BSC		0.0906 BSC	
H	6.70	7.30	0.2638	0.2874
?	0°	10°	0°	10°
F	1.40	1.80	0.0560	0.0702



■ Package Dimension

TO-220

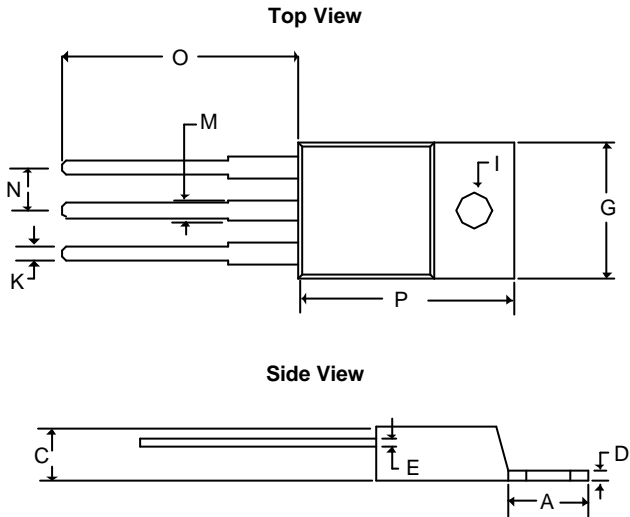

SYMBOLS	MILLIMETERS		INCHES	
	MIN	MAX	MIN	MAX
A	5.58	7.49	0.2197	0.2949
C	3.55	4.83	0.1398	0.1900
D	0.50	1.40	0.0197	0.0550
E	0.30	1.15	0.0118	0.0453
G	9.65	10.67	0.3799	0.4200
I	3.53	4.09	0.1390	0.1610
K	0.50	1.15	0.0197	0.0453
M	1.14	1.78	0.0449	0.0700
N	2.28	2.80	0.0898	0.1102
O	12.70	14.74	0.5000	0.5803
P	14.22	16.51	0.5600	0.6500



www.ame.com.tw
E-Mail: sales@ame.com.tw

Life Support Policy:

These products of AME, Inc. are not authorized for use as critical components in life-support devices or systems, without the express written approval of the president of AME, Inc.

AME, Inc. reserves the right to make changes in the circuitry and specifications of its devices and advises its customers to obtain the latest version of relevant information.

© AME, Inc. , March 2005

Document: 2049/2093-DS8845-B

Corporate Headquarter
AME, Inc.

2F, No.302, Rui-Guang Road, Nei-Hu District
Taipei 114, Taiwan .
Tel: 886 2 2627-8687
Fax: 886 2 2659-2989

U.S.A. (Subsidiary)
Analog Microelectronics, Inc.

3100 De La Cruz Blvd., Suite 201
Santa Clara, CA. 95054-2046
Tel : (408) 988-2388
Fax:(408) 988-2489