



3A LOW DROPOUT POSITIVE FIXED 3.3V REGULATOR

FEATURES

- Guaranteed < 1.3V Dropout at Full Load Current
- Fast Transient Response
- 1% Voltage Reference Initial Accuracy
- Output Current Limiting
- Built-In Thermal Shutdown
- RoHS Compliant

APPLICATIONS

- Standard 3.3V Chip Set and Logic Applications

DESCRIPTION

The APU1030-33 is a low dropout three-terminal fixed 3.3V output regulator with minimum of 3A output current capability. This product is specifically designed to provide well regulated supply for low voltage IC applications requiring 3.3V output. The APU1030-33 is guaranteed to have <1.3V dropout at full load current making it ideal to provide well regulated output with supply voltage as low as 4.6V input.

TYPICAL APPLICATION

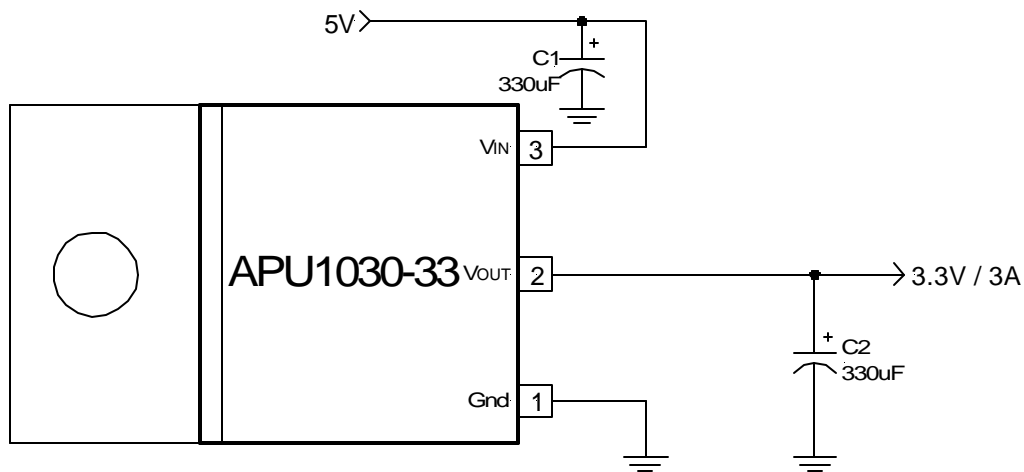

Figure 1 - Typical application of APU1030-33.

PACKAGE ORDER INFORMATION

T _J (°C)	3-PIN PLASTIC TO-220 (P)	2-PIN PLASTIC TO-263 (S)	2-PIN PLASTIC TO-252 (D-Pak)
0 To 150	APU1030P-33	APU1030S-33	APU1030H-33



ABSOLUTE MAXIMUM RATINGS

Input Voltage (V_{IN})	7V
Power Dissipation	Internally Limited
Storage Temperature Range	-65°C To 150°C
Operating Junction Temperature Range	0°C To 150°C

PACKAGE INFORMATION

3-PIN PLASTIC TO-220 (P)	2-PIN PLASTIC TO-263 (S)	2-PIN PLASTIC TO-252 (D-Pak)
<p>$\theta_{JT}=2.7^{\circ}\text{C/W}$ $\theta_{JA}=60^{\circ}\text{C/W}$</p>	<p>$\theta_{JA}=35^{\circ}\text{C/W}$ for 1" Square pad</p>	<p>$\theta_{JA}=70^{\circ}\text{C/W}$ for 0.5" Sq pad</p>

ELECTRICAL SPECIFICATIONS

Unless otherwise specified, these specifications apply over $C_{IN}=1\mu\text{F}$, $C_{OUT}=10\mu\text{F}$, and $T_J=0$ to 150°C . Typical values refer to $T_J=25^{\circ}\text{C}$.

PARAMETER	SYM	TEST CONDITION	MIN	TYP	MAX	UNITS
Output Voltage	V_O	$I_O=10\text{mA}$, $T_J=25^{\circ}\text{C}$, $V_{IN}=5\text{V}$ $I_O=10\text{mA}$, $V_{IN}=5\text{V}$	3.267 3.234	3.300 3.300	3.333 3.366	V
Line Regulation		$I_O=10\text{mA}$, $4.7\text{V}<V_{IN}<7\text{V}$			0.2	%
Load Regulation (Note 1)		$V_{IN}=5\text{V}$, $V_{ADJ}=0$, $10\text{mA}<I_O<3\text{A}$			0.4	%
Dropout Voltage (Note 2)	ΔV_O	Note 2, $I_O=3\text{A}$		1.1	1.3	V
Current Limit		$V_{IN}=5\text{V}$, $\Delta V_O=100\text{mV}$	3.1			A
Minimum Load Current (Note 3)		$V_{IN}=5\text{V}$		5	10	mA
Thermal Regulation		30ms Pulse, $V_{IN}-V_O=3\text{V}$, $I_O=3\text{A}$		0.01	0.02	%/W
Ripple Rejection		$f=120\text{Hz}$, $C_O=25\mu\text{F}$ Tantalum, $I_O=1.5\text{A}$, $V_{IN}-V_O=3\text{V}$	60	70		dB
Adjust Pin Current Change		$I_O=10\text{mA}$, $V_{IN}-V_O=1.5\text{V}$, $T_J=25^{\circ}\text{C}$		0.2	5	μA
Temperature Stability		$V_{IN}=5\text{V}$, $V_{ADJ}=0\text{V}$, $I_O=10\text{mA}$		0.5		%
Long Term Stability		$T_J=125^{\circ}\text{C}$, 1000Hrs		0.3	1	%
RMS Output Noise		$T_J=25^{\circ}\text{C}$, $10\text{Hz}<f<10\text{KHz}$		0.003		% V_O

Note 1: Low duty cycle pulse testing with Kelvin connections is required in order to maintain accurate data.

Note 2: Dropout voltage is defined as the minimum differential voltage between V_{IN} and V_{OUT} required to maintain regulation at V_{OUT} . It is measured when the output voltage drops 1% below its nominal value.

Note 3: Minimum load current is defined as the minimum current required at the output in order for the output voltage to maintain regulation. Typically the resistor dividers are selected such that it automatically maintains this current.



PIN DESCRIPTIONS

PIN #	PIN SYMBOL	PIN DESCRIPTION
1	Gnd	This pin must be connected to ground plane using a low inductance short connection.
2	V _{OUT}	The output of the regulator. A minimum of 10 μ F capacitor must be connected from this pin to ground to insure stability.
3	V _{IN}	The input pin of the regulator. Typically a large storage capacitor is connected from this pin to ground to insure that the input voltage does not sag below the minimum drop out voltage during the load transient response. This pin must always be 1.3V higher than V _{OUT} in order for the device to regulate properly.

BLOCK DIAGRAM

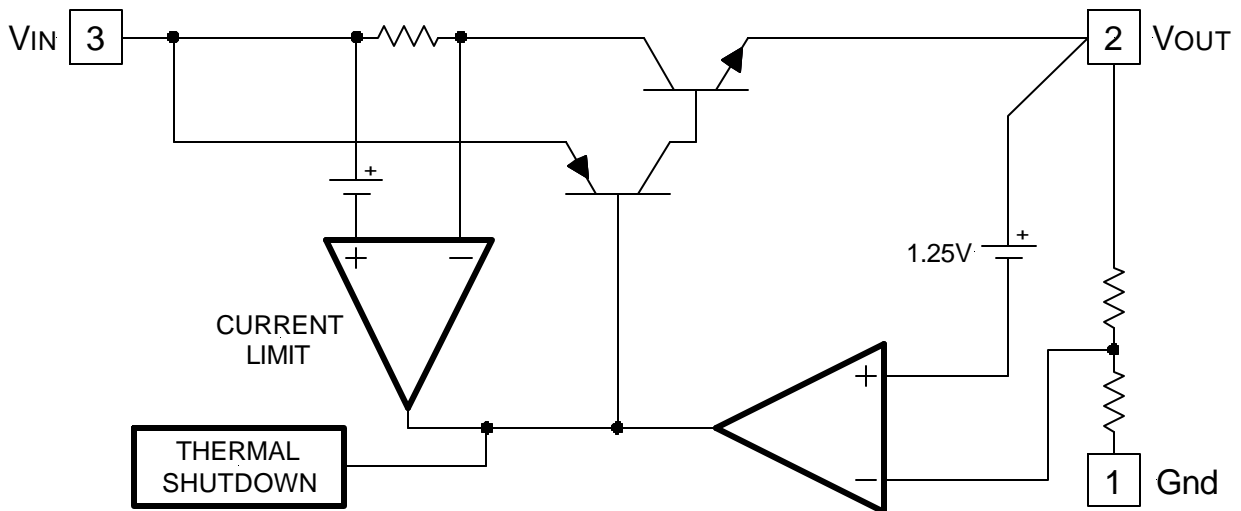

Figure 2 - Simplified block diagram of the APU1030-33.

APPLICATION INFORMATION

Stability

The APU1030-33 requires the use of an output capacitor as part of the frequency compensation in order to make the regulator stable. Typical designs for microprocessor applications use standard electrolytic capacitors with a typical ESR in the range of 50 to 100m Ω and an output capacitance of 500 to 1000 μ F. Fortunately as the capacitance increases, the ESR decreases resulting in a fixed RC time constant. The APU1030-33 takes advantage of this phenomena in making the overall regulator loop stable. For most applications a minimum of 100 μ F aluminum electrolytic capacitor such as Sanyo MVGX series, Panasonic FA series as well as the Nichicon PL series insures both stability and good transient response.