



**1A LOW DROPOUT POSITIVE
FIXED 3.3V REGULATOR**

FEATURES

- Guaranteed < 1.3V Dropout at Full Load Current
- Fast Transient Response
- 2% Voltage Reference Initial Accuracy
- Built-In Thermal Shutdown
- Available in SOT-223, D-Pak, SOT-89, TO-263 and 8-Pin SOIC Surface-Mount Packages

DESCRIPTION

The APU1117-33 is a low dropout three-terminal fixed output regulator with minimum of 1A output current capability. This product is specifically designed to provide well regulated supply for low voltage IC applications such as VGA, sound & DVD cards. The APU1117-33 is guaranteed to have < 1.3V dropout at full load current making it ideal to provide well regulated with 4.75V to 7V input supply. The APU1117-33 is specifically designed to be stable with low cost aluminum capacitors while maintaining stability with low ESR tantalum caps.

APPLICATIONS

- Low Voltage IC Supply Applications
- PC Clock Supply Voltage

TYPICAL APPLICATION

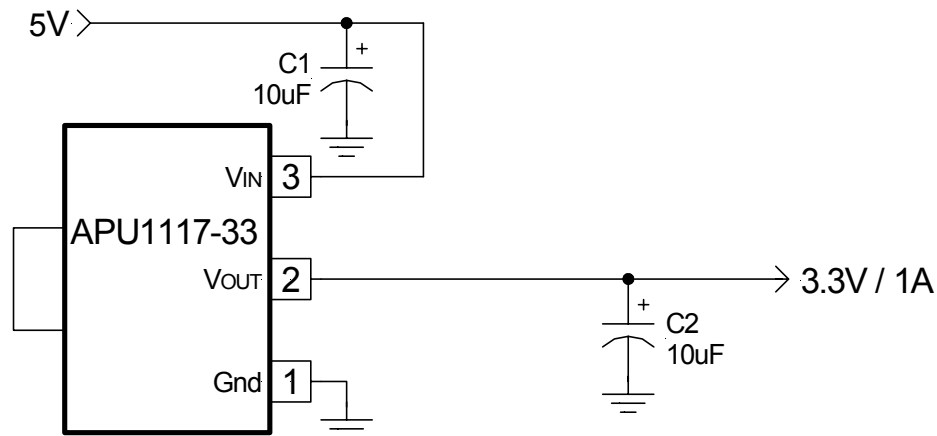

Figure 1 - Typical application of APU1117-33 in a 5V to 3.3V regulator.

PACKAGE ORDER INFORMATION

Leadfree Part

T _J (°C)	2-PIN PLASTIC TO-252 (D-Pak)	3-PIN PLASTIC SOT-223	3-PIN PLASTIC SOT-89	2-PIN PLASTIC TO-263
0 To 150	APU1117H-33	APU1117K-33	APU1117G-33	APU1117S-33



ABSOLUTE MAXIMUM RATINGS

Input Voltage (V _{IN})	7V
Power Dissipation	Internally Limited
Storage Temperature Range	-65°C To 150°C
Operating Junction Temperature Range	0°C To 150°C

PACKAGE INFORMATION

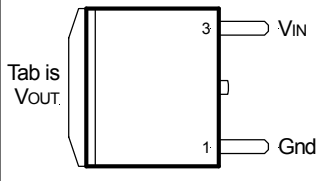
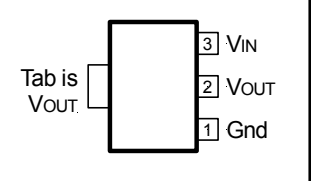
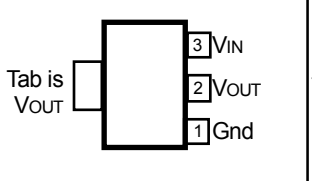
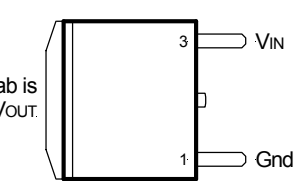
2-PIN PLASTIC TO-252 (D-Pak)	3-PIN PLASTIC SOT-223 (K)	3-PIN PLASTIC SOT-89 (G)	2-PIN PLASTIC TO-263 (S)
 <p>Tab is V_{OUT}.</p> <p>$\theta_{JA}=70^{\circ}\text{C/W}$ for 0.5" Sq pad</p>	 <p>Tab is V_{OUT}.</p> <p>$\theta_{JA}=90^{\circ}\text{C/W}$ for 0.4" Sq pad</p>	 <p>Tab is V_{OUT}.</p> <p>$\theta_{JA}=100^{\circ}\text{C/W}$ for Min" Sq pad</p>	 <p>Tab is V_{OUT}.</p> <p>$\theta_{JA}=35^{\circ}\text{C/W}$ for 1" Sq pad</p>

ELECTRICAL SPECIFICATIONS

Unless otherwise specified, these specifications apply over C_{IN}=1μF, V_{IN}=5V, C_{OUT}=10μF, and T_J=0 to 125°C. Typical values refer to T_J=25°C.

PARAMETER	SYM	TEST CONDITION	MIN	TYP	MAX	UNITS
Output Voltage	V _o	I _o =10mA, T _J =25°C	3.235	3.300	3.365	V
Line Regulation		I _o =10mA, 4.75V<V _{IN} <7V			7	mV
Load Regulation (Note 1)		10mA<I _o <1A			1	%
Dropout Voltage (Note 2)		I _o =1A			1.3	V
Current Limit		ΔV _o =100mV	1.1			A
Thermal Regulation		30ms Pulse, I _o =1A		0.01	0.02	%/W
Ripple Rejection		f=120Hz, C _o =25μF Tantalum, I _o =0.5A	60	70		dB
Temperature Stability		I _o =10mA		0.5		%
Long Term Stability		T _J =125 °C, 1000Hrs		0.3	1	%
RMS Output Noise		T _J =25°C, 10Hz<f<10KHz		0.003		%V _o

Note 1: Low duty cycle pulse testing with Kelvin connections is required in order to maintain accurate data.

Note 2: Dropout voltage is defined as the minimum differential voltage between V_{IN} and V_{OUT} required to maintain regulation at U_T. It is measured when the output voltage drops 1% below its nominal value.



PIN DESCRIPTIONS

PIN#	PIN SYMBOL	PIN DESCRIPTION
1	Gnd	Ground pin. This pin must be connected to ground plane using a low inductance short connection.
2	V _{OUT}	The output of the regulator. This pin is also connected to the tab of the package. An output capacitor must be connected to this pin to insure stability of the regulator.
3	V _{IN}	Input pin of the regulator.

BLOCK DIAGRAM

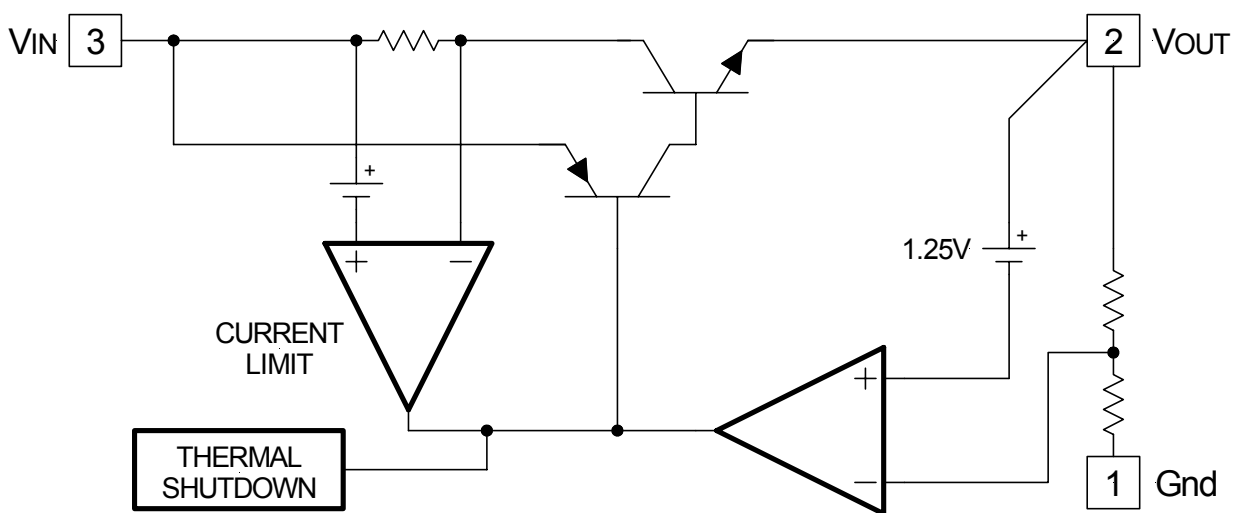

Figure 2 - Simplified block diagram of the APU1117-33.