



1.2V/300mA ULTRA LOW DROPOUT FIXED REGULATORS

FEATURES

- 5-Pin SOT-23 Package
- Stable with 2.2 μ F Ceramic Capacitor
- 2% Voltage Reference Accuracy
- Only 270mV Dropout at 300mA
- 5 μ A Quiescent Current in Shutdown
- Current Limit and Thermal Shutdown
- Logic Input Enable Pin
- RoHS Compliant

APPLICATIONS

- Laptop, Notebook & Palmtop computers
- Battery Powered Equipments
- PCMCIA Vcc & Vpp Regulator
- Consumer Electronics
- High Efficiency Linear Power Supplies

DESCRIPTION

The APU8812 device is an efficient linear voltage regulator with better than 2% initial voltage accuracy, very low dropout voltage and very low ground current designed especially for hand held, battery powered applications. Other features of the device are: TTL compatible enable/shutdown control input, current limiting and thermal shutdown.

The APU8812 is available in fixed output voltage versions in a small 5-Pin SOT-23 package.

TYPICAL APPLICATION

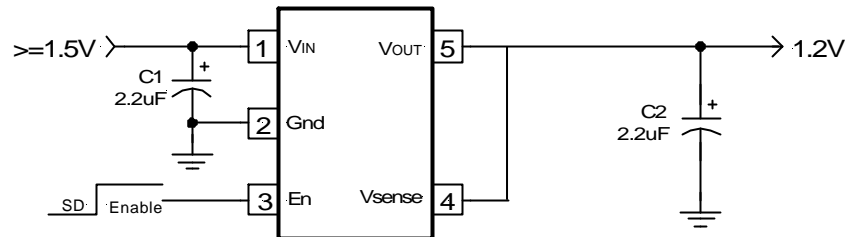

Figure 1 - Typical application of the APU8812 fixed voltage regulator.

PACKAGE ORDER INFORMATION

T _J (°C)	5-PIN SOT-23	OUTPUT VOLTAGE
0 To 125	APU8812Y5	1.2V



ABSOLUTE MAXIMUM RATINGS

Input Voltage (V_{IN})	10V
Enable Input Voltage	10V
Storage Temperature Range	-65°C To 150°C
Operating Junction Temperature Range	0°C To 150°C

PACKAGE INFORMATION

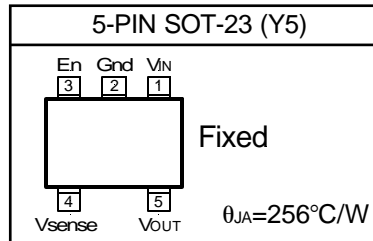

ELECTRICAL SPECIFICATIONS

Unless otherwise specified, these specifications apply over $C_{IN}=C_{O}=2.2\mu\text{F}$, $I_{O}=100\mu\text{A}$, $V_{IN}=1.8\text{V}$, $C_{BYP}=470\text{pF}$, $V_{ENB}=1.8\text{V}$ and $T_A=25$. Typical values refer to $T_A=25$. Low duty cycle pulse testing is used which keeps junction and case temperatures equal to the ambient temperature.

PARAMETER	SYM	TEST CONDITION	MIN	TYP	MAX	UNITS
Reference Voltage	V_O		-2		2	%
Line Regulation	ΔV_I	$V_O + 1\text{V} < V_{IN} < 10\text{V}$		0.005		%/V
Load Regulation (Note 1)	ΔV_L	$1\text{mA} < I_O < 100\text{mA}$ $100\text{mA} < I_O < 300\text{mA}$		0.8 0.1		%
Dropout Voltage (Note 2)	$\Delta V_{I(O)}$	$I_O=100\mu\text{A}$ $I_O=100\mu\text{A}$ (Note 4) $I_O=50\text{mA}$ $I_O=50\text{mA}$ (Note 4) $I_O=150\text{mA}$ $I_O=150\text{mA}$ (Note 4) $I_O=300\text{mA}$ $I_O=300\text{mA}$ (Note 4)		10 13 85 100 170 204 270 324	50 70 110 140 220 260 350 400	mV
Ground Current (Note 3)	I_Q	$V_{EN}=2\text{V}$, $I_O=100\mu\text{A}$ $I_O=100\mu\text{A}$ (Note 4) $I_O=50\text{mA}$ $I_O=50\text{mA}$ (Note 4) $I_O=150\text{mA}$ $I_O=150\text{mA}$ (Note 4) $I_O=300\text{mA}$ $I_O=300\text{mA}$ (Note 4)		120 240 420 540 2200 2900 7200 9300	160 600 2900 9500	μA
Ground Current-SD Activated	$I_{Q(SD)}$	$V_{EN}=0\text{V}$ to 0.8V or Open		5		μA
Current Limit	I_{CL}	$V_O=0\text{V}$	320	420		mA
Thermal Regulation	ΔV_P	$V_{IN}=10\text{V}$, $I_O=150\text{mA}$, 10ms Pulse		0.05		%/W
Adjust Pin Current	I_{ADJ}	$V_{IN}=2.5\text{V}$, $V_O=V_{ADJ}$		0.1		μA
Enable Pin Input LO Voltage	$V_{EN(L)}$	Regulator OFF			0.8	V
Enable Pin Input HI Voltage	$V_{EN(H)}$	Regulator ON	1.2			V
Enable Pin Input LO Current		$V_{EN(L)}=0\text{V}$ to 0.8V		0.01		μA
Enable Pin Input HI Current		$V_{EN(H)}=1.2\text{V}$ to V_{IN}		20		μA



Note 1: Low duty cycle pulse testing with Kelvin connections is required in order to maintain accurate data.

Note 2: Dropout voltage is defined as the minimum differential voltage between V_{IN} and V_{OUT} required to maintain regulation at V_{OUT} . It is measured when the output voltage drops 1% below its nominal value.

Note 3: Ground current is the regulator quiescent current plus the pass transistor current. The total current from the supply is the sum of the load current plus the ground pin current.

Note 4: The specification applies for the junction temperature of 0 to +125°C.

PIN DESCRIPTIONS

PIN #	PIN SYMBOL	PIN DESCRIPTION
1	V_{IN}	The input pin of the regulator. Typically a large storage capacitor is connected from this pin to ground to insure that the input voltage does not sag below the minimum drop out voltage during the load transient response. This pin must always be higher than V_{OUT} by at least the amount of the dropout voltage and some margin in order for the device to regulate properly.
2	Gnd	Ground pin. This pin must be connected to the lowest potential in the system and all other pins must be at higher potential with respect to this pin.
3	En	Enable pin. A low signal or left open on this pin shuts down the output. This pin must be tied HI or to V_{IN} for normal operation.
4	Vsense	must be connected from this pin to V_{OUT}
5	V_{OUT}	The output of the regulator. A minimum of 2.2 μ F with max ESR of 1 Ω capacitor must be connected from this pin to ground to insure stability.



BLOCK DIAGRAM

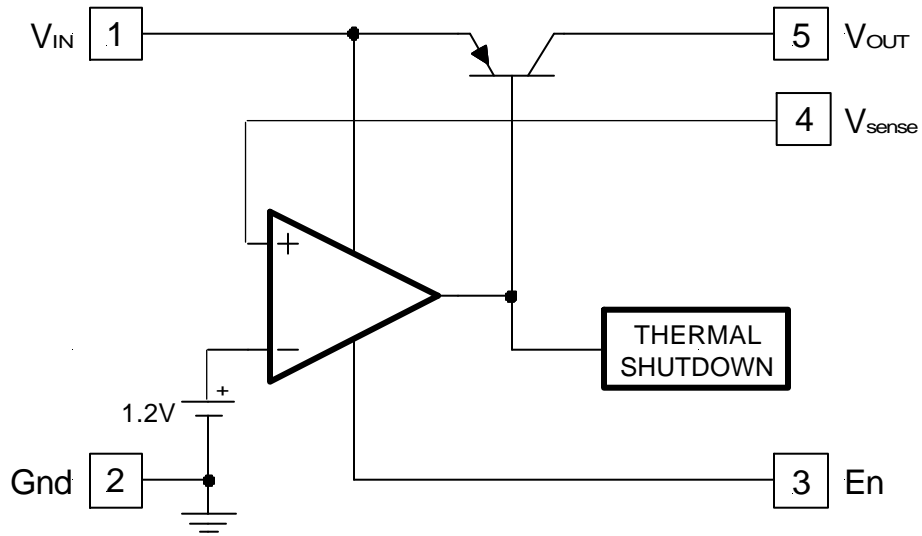

Figure 2 - APU8812 Fixed output 1.2V block diagram.