

ULTRA-FAST PLASTIC RECTIFIER
VOLTAGE RANGE 50 TO 1000 Volts
CURRENT 3.0 Ampere

FEATURES

- * Ultra-fast recovery time for high efficiency
- * Glass Passivated Chip junction
- * Excellent high temperature switching
- * Low reverse leakage current
- * Low forward voltage drop
- * High current capability

MECHANICAL DATA

- * Case : JEDEC DO-15ic
- * Epoxy: UL94V-O rate flame retardant
- * Terminals : Solderable Per MIL-STD-202 Method 208
- * Polarity : Color band denotes cathode end
- * Mounting position: Any
- * Weight : 0.015 ounces,0.4 grams

Plating pb free

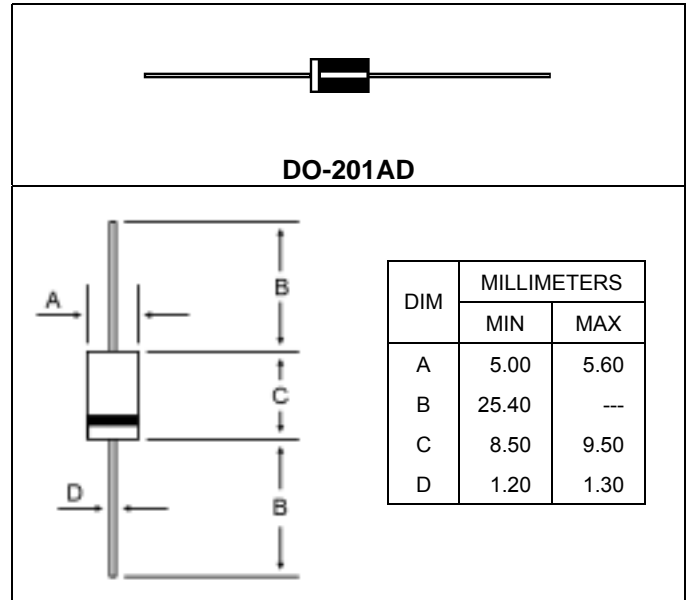

MAXIMUM RATINGS AND ELECTRICAL CHARACTERISTICS

- * Rating at 25 °C ambient temperature unless otherwise specified
- * Single phase, half wave, 60Hz, resistive or inductive load.
- * For capacitive load derate current by 20 %

Characteristic	Symbol	UF	UF	UF	UF	UF	UF	UF	UF	UF	Unit
		5400M-T52	5401M-T52	5402M-T52	5403M-T52	5404M-T52	5405M-T52	5406M-T52	5407M-T52	5408M-T52	
Peak Repetitive Reverse Voltage Working Peak Reverse Voltage DC Blocking Voltage	V_{RRM} V_{RWM} V_R	50	100	200	300	400	500	600	800	1000	V
RMS Reverse Voltage	$V_{R(RMS)}$	35	70	140	210	280	350	420	560	700	V
Average Rectifier Forward Current Per Leg $T_C=55$	$I_{F(AV)}$	3.0									A
Non-Repetitive Peak Surge Current (Surge applied at rate load conditions halfwave, single phase, 60Hz)	I_{FSM}	150									A
Maximum Instantaneous Forward Voltage ($I_F=3.0$ Amp $T_C=25$)	V_F	1.0			1.7						V
Maximum Instantaneous Reverse Current (Rated DC Voltage, $T_C=25$) (Rated DC Voltage, $T_C=100$)	I_R	10 75			10 200						μ A
Reverse Recovery Time ($I_F=0.5$ A, $I_R=1.0$, $I_{rr}=0.25$ A)	T_{rr}	50			75						ns
Typical Junction Capacitance (Reverse Voltage of 4 volts & $f=1$ MHz)	C_j	45			36						pF
Typical Thermal Resistance (1)	$R_{\theta Ja}$ $R_{\theta jl}$	20 8.5									/W
Operating and Storage Junction Temperature Range	T_J, T_{stg}	-65 to +150									

Notes:

- (1) Thermal resistance from junction to lead and from junction to ambient with 0.375"(9.5mm) lead length, both leads attached to heatsink

UF5400M-T52 Thru UF5408M-T52

FIG-1 TYPICAL FORWARD CHARACTERISTICS

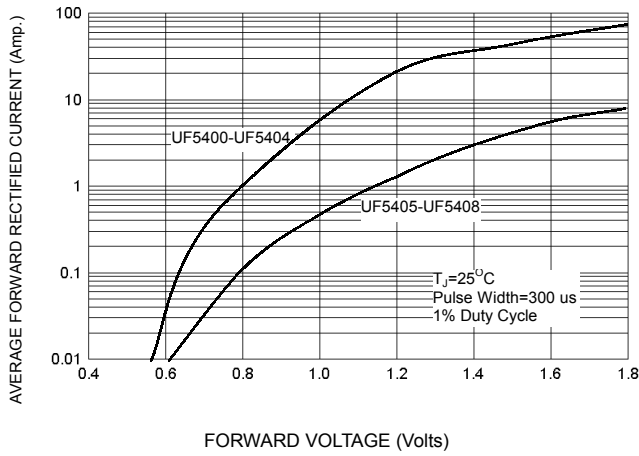

FIG-3 FORWARD CURRENT DERATING CURVE

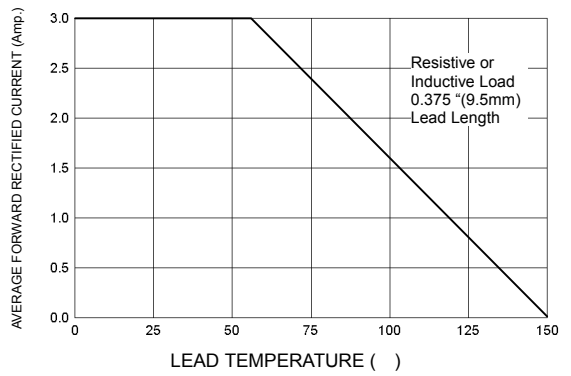

FIG-2 TYPICAL REVERSE CHARACTERISTICS

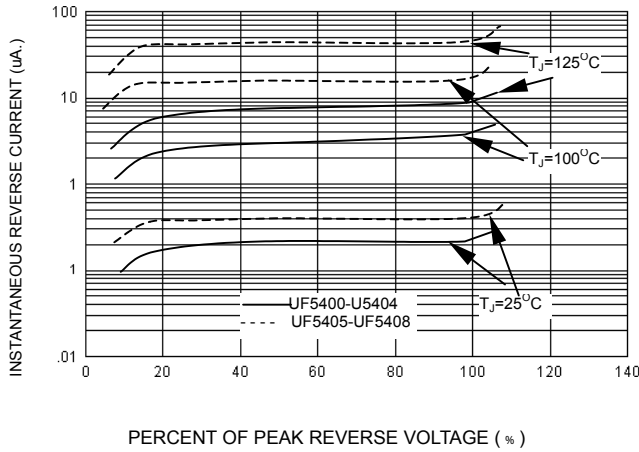

FIG-4 TYPICAL JUNCTION CAPACITANCE

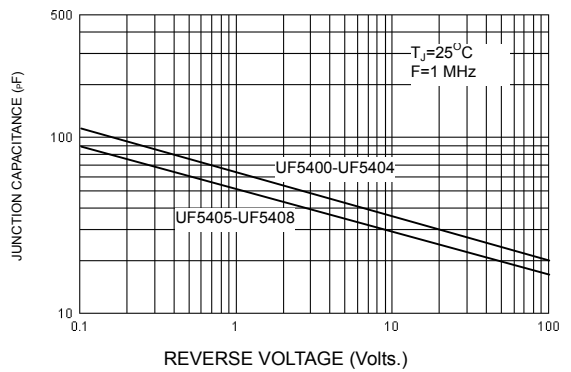
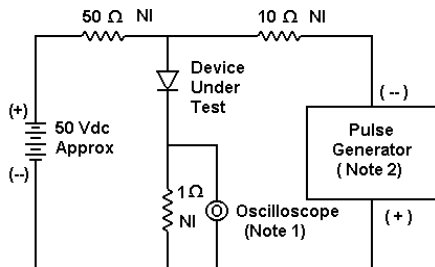
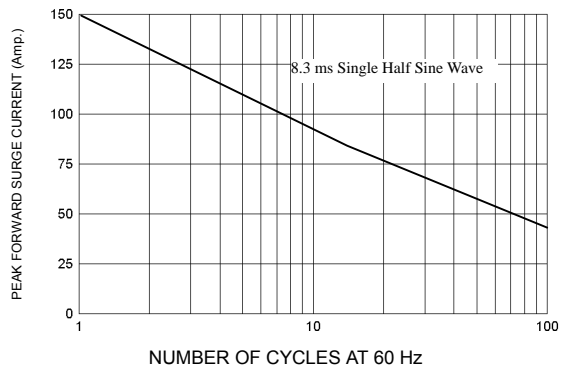
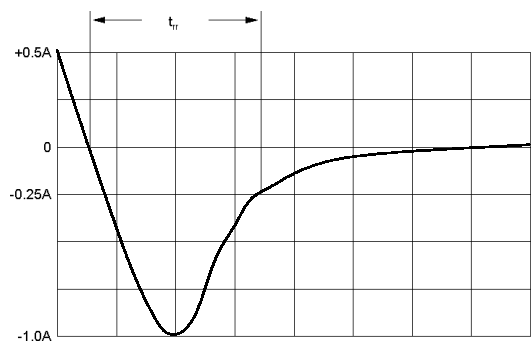

FIG-5 PEAK FORWARD SURGE CURRENT



- Notes:
 1. Rise Time = 7 ns max. Input Impedance = 1 M Ω , 22 pF
 2. Rise Time = 10 ns max. Input Impedance = 50 Ω



Set time base for 10/20 ns/cm

FIG-6 Reverse Recovery Time Characteristic and Test Circuit Diagram

UF5400M-T52 Thru UF5408M-T52

Taping Specifications

Description	Dimension	Case Style	Specification(mm)
Component Pitch	A	DO-15, DO-35, DO-41, DO-7, A-405, R-3, R-1	5.0±0.5
		5KP, DO-201AD, R-6	10.0±0.5
Inside Tape Spacing	B	All	50±0.1
Lead To Lead Eccentricity	$[C_1 - C_2]$	All	1.0 Max.
Lead Extension	D	All	0.5 Max.
Lead Bending	E	All	1.2 Max.
Cumulative Pitch	G	All	1.5 per 10 pitch
Exposed Adhesive	H	All	0.8 Max.
Tape Width	J	All	6.0±0.4
Tape Leader	Beginning and end of reel or ammo pack		300.0 Min.
Empty Spaces	Consecutive missing components not allowed		<0.1%
Polarity Marking	All polarized components shall be oriented in the same direction. The cathode tape shall be colored and the anode tape shall be white or light beige.		

Dimensions apply to both sides of the reel

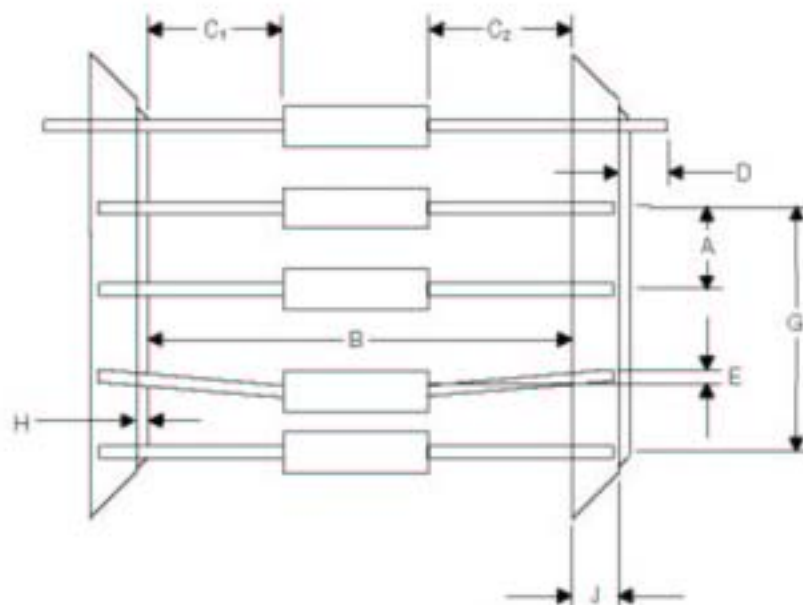

UF5400-T52 Thru UF5408-T52

Mechanic Operation UF54xx Series Diode

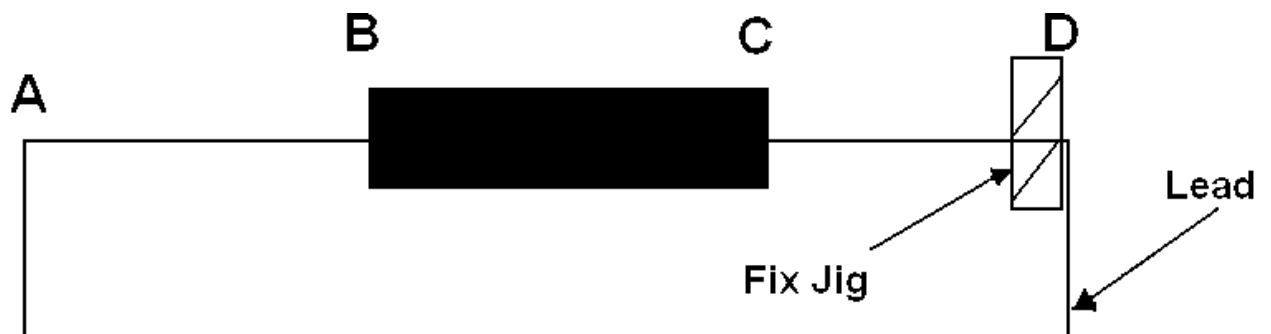

- 1) The bending point of lead from the diode body(AB or CD) should not be less than 3.5 mm.
- 2) Leading bending and forming shall be executed in such as figure above, Fixing the lead before the process, then would not impose any mechanical stress on the diode body, or else it will affect the chips.
- 3) Can not bend both side of leads at the same time, should bend it one by one.