

300V, 20A Q-Series Common-Cathode Rectifier

Product Summary

$I_{F(AVG)}$ per diode	10	A
V_{RRM}	300	V
Q_{RR} (Typ at 125 °C)	38	nC
I_{RRM} (Typ at 125 °C)	2.3	A
Softness t_b/t_a (Typ at 125 °C)	0.7	

Pin Assignment

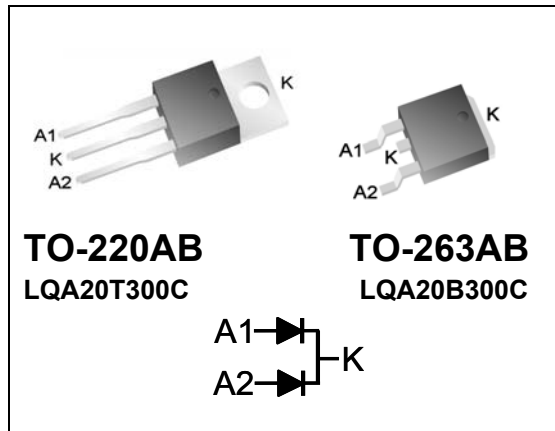

RoHS Compliant

Package uses Lead-free plating and "Green" mold compound

General Description

Utilizing proprietary Qspeed technology this device has the lowest Q_{RR} of any 300V Silicon diode. Its recovery characteristics increase efficiency, reduce EMI and eliminate snubbers.

Applications

- AC/DC and DC/DC output rectification
 - Output & freewheeling diodes
- Motor drive circuits
- DC-AC inverters

Features

- Low Q_{RR} , Low I_{RRM} , Low t_{RR}
- High di_f/dt capable (1000A/ μ s)
- Soft recovery

Benefits

- Increases efficiency
 - Eliminates need for snubber circuits
 - Reduces EMI filter component size & count
- Enables extremely fast switching

Absolute Maximum Ratings

Absolute maximum ratings are the values beyond which the device may be damaged or have its useful life impaired. Functional operation under these conditions is not implied.

Symbol	Parameter	Conditions	Rating	Units
V_{RRM}	Peak repetitive reverse voltage		300	V
$I_{F(AVG)}$	Average forward current	Per Diode, $T_J = 150\text{ °C}$, $T_C = 115\text{ °C}$	10	A
		Per Device, $T_J = 150\text{ °C}$, $T_C = 115\text{ °C}$	20	A
I_{FSM}	Non-repetitive peak surge current	60 Hz, $\frac{1}{2}$ cycle	80	A
I_{FSM}	Non-repetitive peak surge current	$\frac{1}{2}$ cycle of $t = 28\text{ }\mu$ s Sinusoid, $T_C = 25\text{ °C}$	350	A
T_J	Maximum junction temperature		150	°C
T_{STG}	Storage temperature		-55 to 150	°C
	Lead soldering temperature	Leads at 1.6mm from case, 10 sec	300	°C
P_D	Power dissipation	$T_C = 25\text{ °C}$	52	W

Thermal Resistance

Symbol	Resistance from:	Conditions	Rating	Units
$R_{\theta JA}$	Junction to ambient	TO-220AB (only)	62	°C/W
$R_{\theta JC}$	Junction to case	Per Diode	2.4	°C/W
		Per Device	1.2	°C/W

Electrical Specifications at T_J= 25 °C (unless otherwise specified)

Symbol	Parameter	Conditions	Min	Typ	Max	Units	
DC Characteristics per diode							
I _R	Reverse current per diode	V _R = 300 V, T _J = 25 °C	-	-	25	μA	
		V _R = 300 V, T _J = 125 °C	-	0.32	-	mA	
V _F	Forward voltage per diode	I _F = 10 A, T _J = 25 °C	-	1.58	1.9	V	
		I _F = 10 A, T _J = 150 °C	-	1.36	-	V	
C _J	Junction capacitance per diode	V _R = 10 V, 1 MHz	-	33	-	pF	
Dynamic Characteristics per diode							
t _{RR}	Reverse recovery time, per diode	dI _F /dt =200 A/μs V _R =200, I _F =10 A	T _J =25 °C	-	12.6	-	ns
			T _J =125 °C	-	24	-	ns
Q _{RR}	Reverse recovery charge, per diode	dI _F /dt =200 A/μs V _R =200, I _F =10 A	T _J =25 °C	-	10.2	16	nC
			T _J =125 °C	-	38	-	nC
I _{RRM}	Maximum reverse recovery current, per diode	dI _F /dt =200 A/μs V _R =200, I _F =10 A	T _J =25 °C	-	1.3	1.7	A
			T _J =125 °C	-	2.3	-	A
S	Softness per diode= $\frac{t_b}{t_a}$	dI _F /dt =200 A/μs V _R =200, I _F =10 A	T _J =25 °C	-	0.7	-	
			T _J =125 °C	-	0.7	-	

Note to component engineers: Q-Series rectifiers employ Schottky technologies in their design and construction. Therefore, component engineers should plan their test setups to be similar to traditional Schottky test setups. (For further details, see Qspeed application note AN-300.)

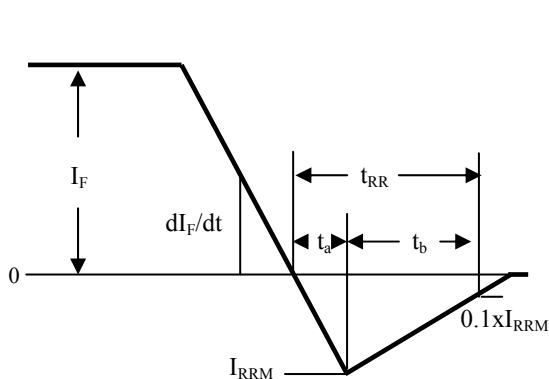

Figure 1. Reverse Recovery Definitions

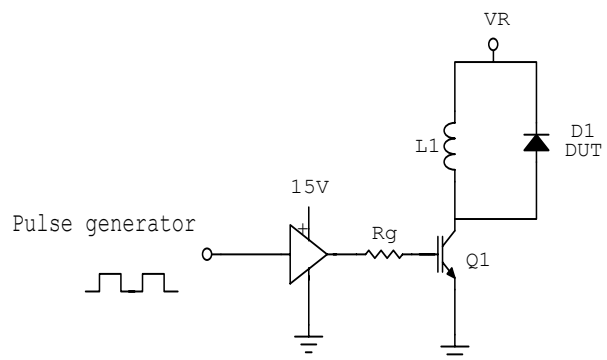

Figure 2. Reverse Recovery Test Circuit

Specifications per diode at $T_J = 25\text{ }^\circ\text{C}$ (unless otherwise specified)

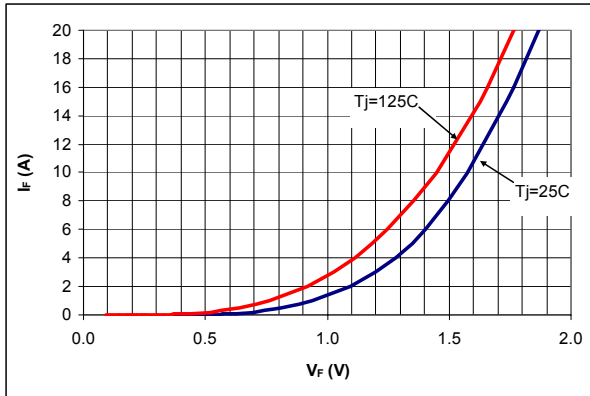

Figure 3. Typical I_F vs V_F

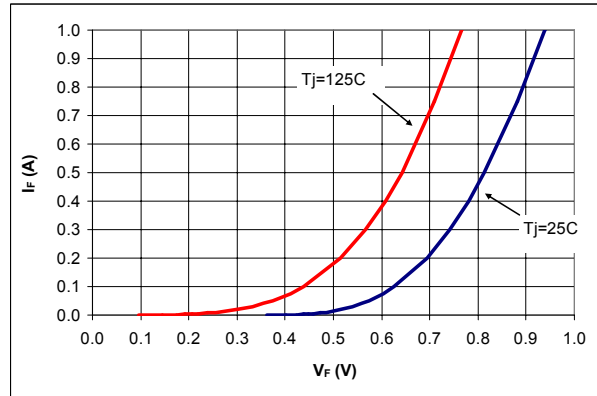

Figure 4. Typical I_F vs V_F

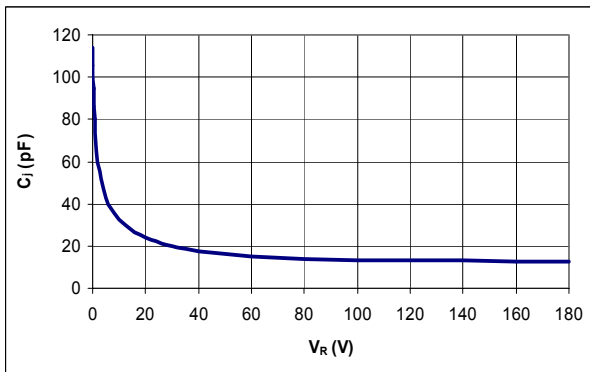

Figure 5. Typical C_j vs V_R

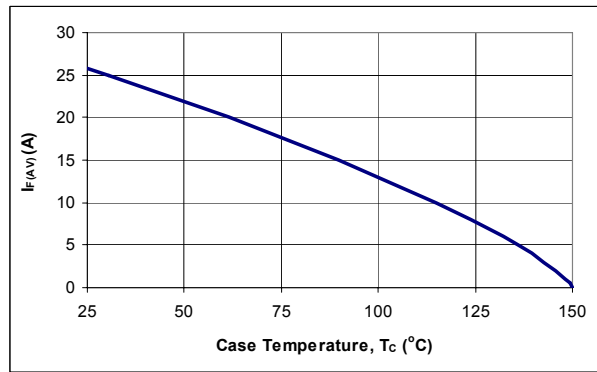

Figure 6. DC Current Derating Curve

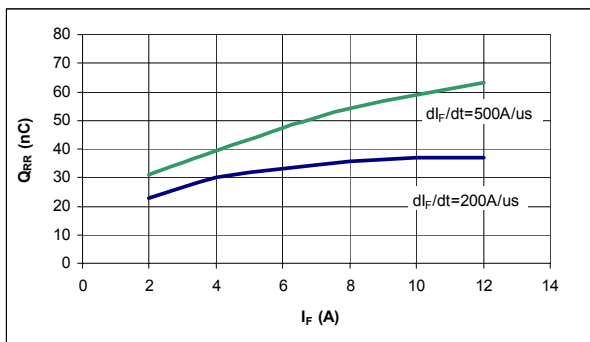

Figure 7. Typical Q_{RR} vs I_F at $T_J = 125\text{ }^\circ\text{C}$

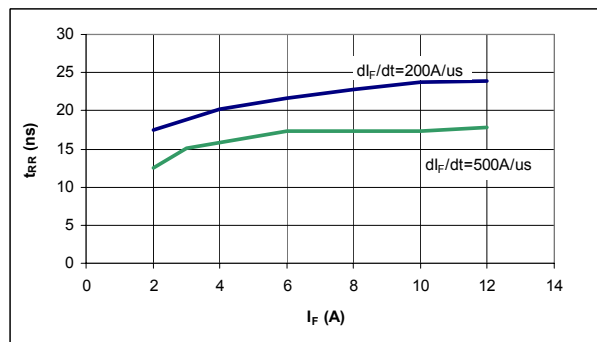

Figure 8. Typical t_{RR} vs I_F at $T_J = 125\text{ }^\circ\text{C}$

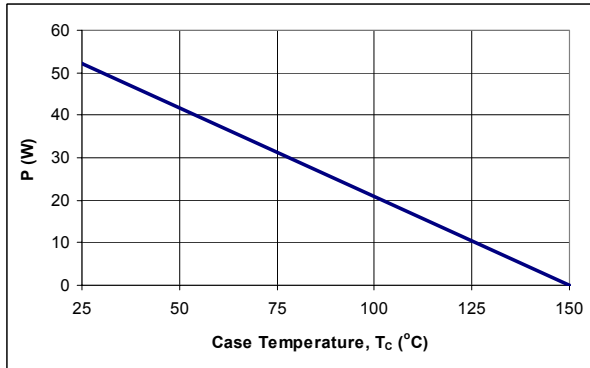

Figure 9. Power Derating Curve

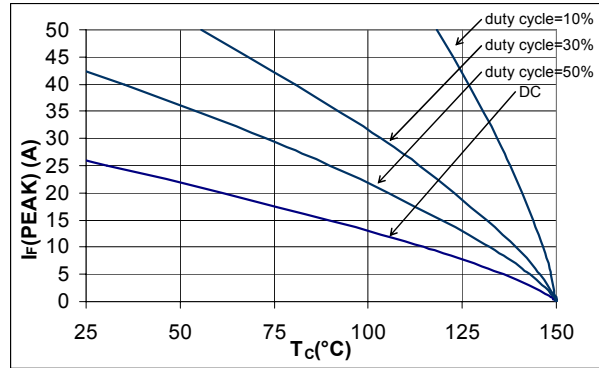

Figure 10. $I_F(\text{Peak})$ vs T_C , $f=70$ kHz

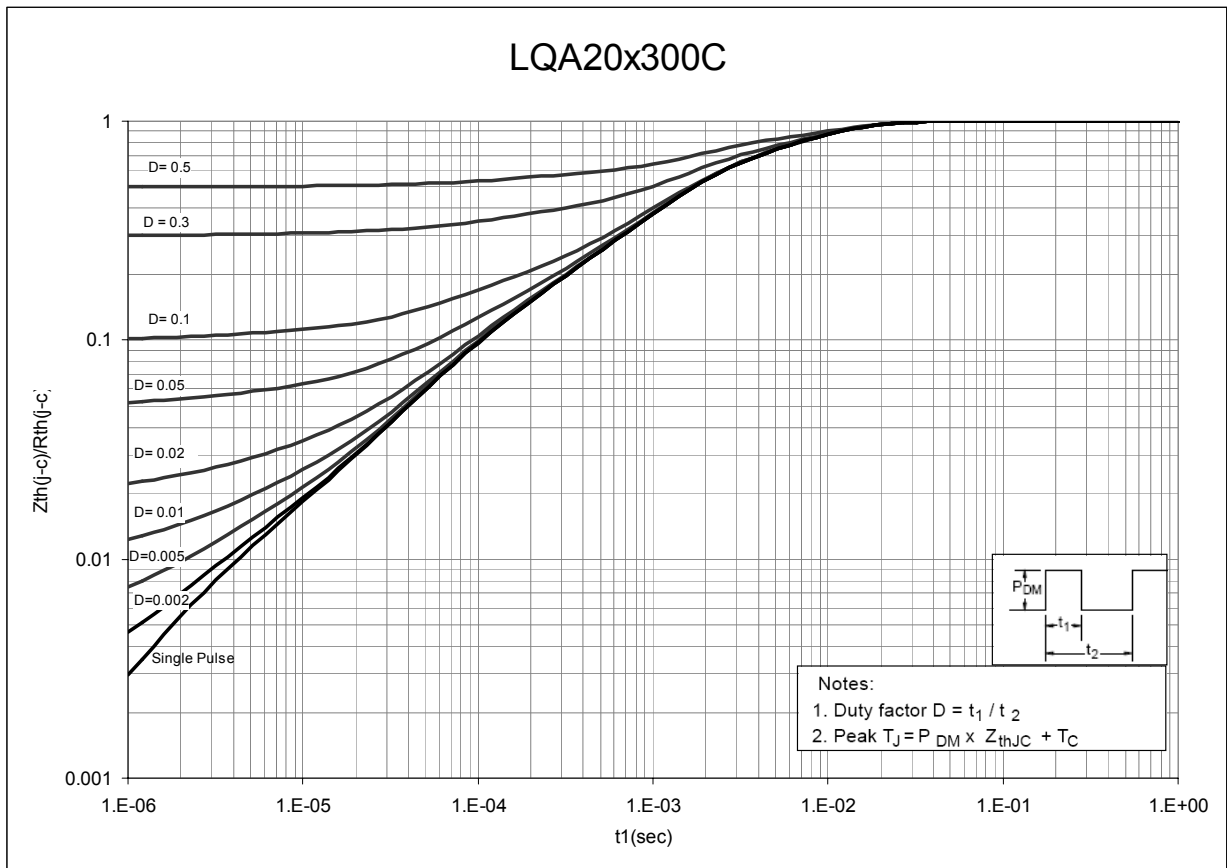

Figure 11. Normalized Maximum Transient Thermal Impedance

Ordering Information

Part Number	Package	Packing
LQA20T300C	TO-220AB	50 units/tube
LQA20B300C	TO-263AB	50 units/tube, 800 units/reel

The information contained in this document is subject to change without notice.

LIFE SUPPORT POLICY

This product is not designed for use in life support appliances, devices or systems where malfunction of the product may result in personal injury. Qspeed Semiconductor cannot be held liable for damages or injuries that might result from the failure of the Qspeed Semiconductor product in such applications.