

600V, 4A Qspeed “X-Series” PFC Rectifier

Product Summary

$I_{F(AV)}$	4	A
V_{RRM}	600	V
Q_{RR} (Typ at 125°C)	60	nC
I_{RRM} (Typ at 125°C)	2.75	A
Softness t_b/t_a (Typ at 125°C)	0.8	

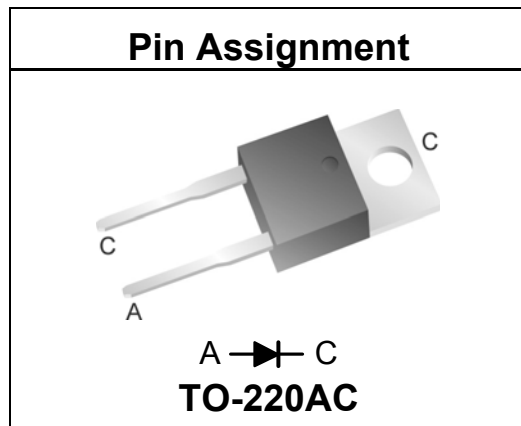

RoHS Compliant

Package uses Lead-free plating and Green mold compound.

General Description

Using advanced Silicon technology, the X-Series power rectifier is specifically designed to offer better performance in PFC Boost applications. When compared with other Silicon rectifier technologies, X-Series rectifiers offer higher efficiencies, lower surrounding device temperatures, and/or better EMI performance, at an attractive price point.

Utilizing proprietary Qspeed Silicon technology, this device offers a low reverse recovery current. Its soft recovery reduces electrical stress on surrounding circuit elements (especially the switching transistors), and helps to reduce heat, lower unnecessary component guard-banding and snubbing, and increase efficiency.

Applications

- Power Factor Correction (PFC) Boost Diode
- AC/DC power supplies and adapters
- Freewheeling diodes

Features

- Designed for PFC operation
- Low Q_{RR} , Low I_{RRM} , Low EMI
- High dI/dt capable (1000A/us)
- Soft recovery
- Enables snubberless operation for cost savings

Absolute Maximum Ratings

Absolute maximum ratings are the values beyond which the device may be damaged or have its useful life impaired. Functional operation under these conditions is not implied.

Symbol	Parameter	Conditions	Rating	Units
V_{RRM}	Peak repetitive reverse voltage		600	V
$I_{F(AV)}$	Average forward current	$T_J = 150^\circ\text{C}$, $T_C = ^\circ\text{C}$	4	A
I_{FSM}	Non-repetitive peak surge current	60Hz, 1/2 cycle	TBD	A
T_J	Maximum junction temperature		150	°C
T_{STG}	Storage temperature		-55 to 150	°C
	Lead soldering temperature	Leads at 1.6mm from case, 10 sec	300	°C
P_D	Power dissipation	$T_C = 25^\circ\text{C}$	TBD	W

Thermal Resistance

Symbol	Resistance from:	Conditions	Rating	Units
$R_{\theta JA}$	Junction to ambient	TO-220	62	°C/W
$R_{\theta JC}$	Junction to case	TO-220	1.9 (Typical)	°C/W

Electrical Specifications @ $T_J = 25^\circ\text{C}$ (unless otherwise specified)

Symbol	Parameter	Conditions	Min	Typ	Max	Units	
DC Characteristics							
I_R	Reverse current	$V_R = 600\text{V}, T_J = 25^\circ\text{C}$	-	-	150	μA	
		$V_R = 600\text{V}, T_J = 125^\circ\text{C}$	-	0.45	-	mA	
V_F	Forward voltage	$I_F = 4\text{A}, T_J = 25^\circ\text{C}$	-	2.2	-	V	
		$I_F = 4\text{A}, T_J = 150^\circ\text{C}$	-	1.85	-	V	
C_J	Junction capacitance	$V_R = 10\text{V}, 1\text{MHz}$	-	21	-	pF	
Dynamic Characteristics							
t_{RR}	Reverse recovery time	$dI/dt = 200\text{A}/\mu\text{s}$ $V_R = 400, I_F = 4\text{A}$	$T_J = 25^\circ\text{C}$	-	21.0	-	ns
			$T_J = 125^\circ\text{C}$	-	30.5	-	ns
Q_{RR}	Reverse recovery charge	$dI/dt = 200\text{A}/\mu\text{s}$ $V_R = 400, I_F = 4\text{A}$	$T_J = 25^\circ\text{C}$	-	26.5	-	nC
			$T_J = 125^\circ\text{C}$	-	60.0	-	nC
I_{RRM}	Maximum reverse recovery current	$dI/dt = 200\text{A}/\mu\text{s}$ $V_R = 400, I_F = 4\text{A}$	$T_J = 25^\circ\text{C}$	-	1.92	-	A
			$T_J = 125^\circ\text{C}$	-	2.75	-	A
S	Softness factor = $\frac{t_b}{t_a}$	$dI/dt = 200\text{A}/\mu\text{s}$ $V_R = 400, I_F = 4\text{A}$	$T_J = 25^\circ\text{C}$	-	0.8	-	
			$T_J = 125^\circ\text{C}$	-	0.8	-	

Note to component engineers: Qspeed X-Series rectifiers employ Schottky technologies in their design and construction. Component engineers therefore should plan their test setups to be similar to traditional Schottky test setups. (For further details, see Qspeed application note AN-300.)

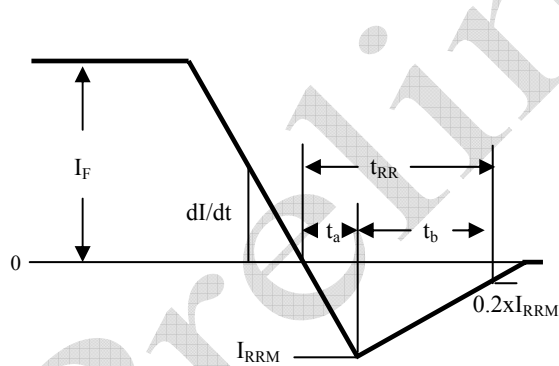

Figure 1. Reverse Recovery Definitions

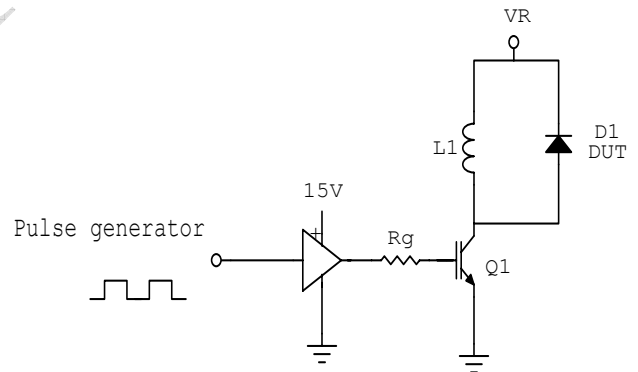

Figure 2. Reverse Recovery Test Circuit