



偉詮電子股份有限公司  
**Weltrend Semiconductor, Inc.**

---

**WT7520**

**PC POWER SUPPLY PWM SUPERVISOR**

**Data Sheet**

**REV. 1.00**

**June 16, 2006**

The information in this document is subject to change without notice.  
©Weltrend Semiconductor, Inc. All Rights Reserved.

---

新竹市科學工業園區工業東九路 24 號 2 樓  
2F, No. 24, Industry E. 9<sup>th</sup> RD., Science-Based Industrial Park, Hsin-Chu, Taiwan  
TEL:886-3-5780241 FAX:886-3-5794278.5770419  
Email:support@weltrend.com.tw

## GENERAL DESCRIPTION

The WT7520 is a pulse-width modulation (PWM) control circuit with complete protection circuits for used in the SMPS (Switched Mode Power Supply). It contains various functions, which are Over Voltage Protection, Under Voltage Protection, Power Good Output (PGO), Remote On/Off control and etc. It can minimize external components of switching power supply systems in personal computer.

Over Voltage Protection (OVP) monitors 3.3V, 5V, 12V and PT input voltage level. Under Voltage Protection (UVP) monitors 3.3V, 5V and 12V input voltage level. Power Good Output monitors the voltage level of power supply.

## FEATURES

- Complete PWM Control and Protection Circuitry
- Over Voltage Protection for 3.3V / 5V / 12V / PT
- Under Voltage Protection for 3.3V / 5V / 12V
- 280ms PG Time Delay
- Power Good Output is Open Drain Output
- PWM Control Output are Open Drain Output
- 280 mS Time Delay for UVP
- Remote ON/OFF function De-bounce Time
- Soft-Start function built-in
- 16-Pin Dual In-line Package

## PIN CONFIGURATION

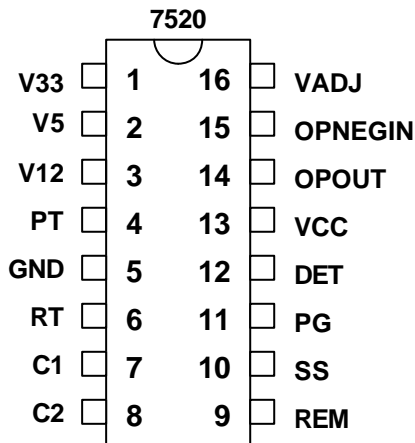

Ordering Number	Package Type
WT7520	DIP 16

**PIN DESCRIPTION**

Pin No.	Pin Name	TYPE	FUNCTION
1	V33	I	OVP/UVI input FOR 3.3V.
2	V5	I	OVP/UVI input for 5V.
3	V12	I	OVP/UVI input for 12V.
4	PT	I	Extra OVP protection input.
5	GND	P	Ground.
6	RT	O	Oscillation frequency set by external resistor.
7	C1	O	PWM open drain output 1.
8	C2	O	PWM open drain output 2.
9	REM	I	Remote on/off input. REM="low" that means the main SMPS is turned-on. REM="high", the main SMPS is turned-off.
10	SS	O	Soft start function set by external capacitor.
11	PG	O	Power good signal. PG= "high" means "power good". PG= "low" means "power fail".
12	DET	I	Extra protection input.
13	VCC	P	Supply voltage.
14	OPOUT	O	OP compensation output.
15	OPNEGIN	I	OP compensation negative input.
16	VADJ	I	OP compensation positive input , feedback voltage sense input.

\*The difference between WT7905 and WT7520

ITEM	WT7905	WT7520
Pin-6 (PWM frequency)	CT; external capacitor	RT; external resistor (ex. 120k )
Pin-10	TPG; external capacitor (PG delay-time function)	SS; external capacitor (Soft-start function)
OVP-3.3V,5V,12V	100us (Typ.)	510us (Typ.)
UVP-3.3V,5V,12V	100us (Typ.)	110us (Typ.)
Soft-Start function	Set by internal circuit	Set by external capacitor (Pin-10:SS)
Pin-4 (PT)	PT default 0.8V (with internal voltage divided resistors)	PT default 0.8V. (with internal voltage divided resistors) (24K+4.6K)

## BLOCK DIAGRAM

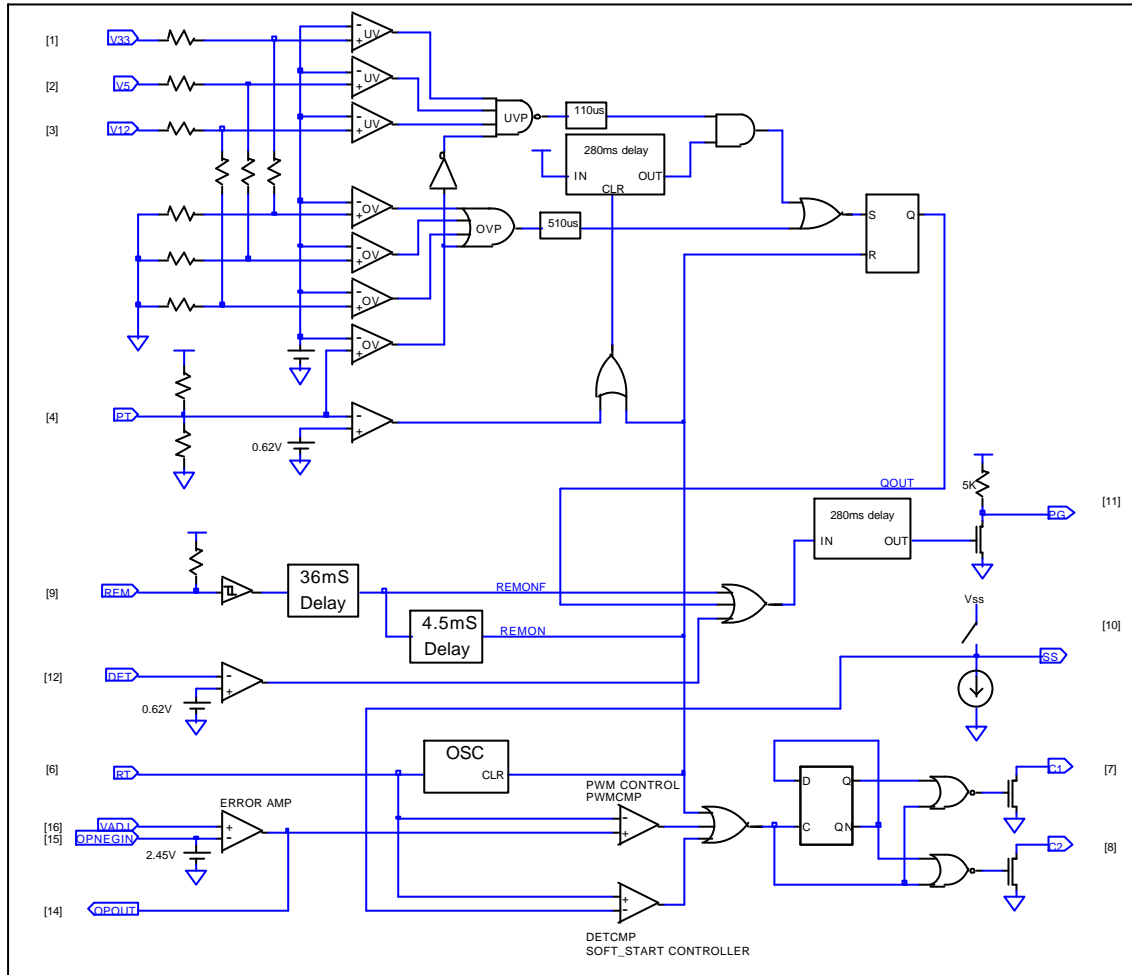

## ABSOLUTE MAXIMUM RATINGS, VCC=5.5V

CHARACTERISTICS	SYMBOL	VALUE	Unit
Supply voltage	VCC	5.5	V
Drain output voltage	Vcc1, Vcc2	5.5	V
Drain output current	Icc1, Icc2	200	mA
Power dissipation	Pd	200	mW
Operating temperature	Topr	-10 ~ +70	
Storage temperature	Tstg	-65 ~ +150	

**ELECTRICAL CHARACTERISTICS,  $T_A=25$  ,  $V_{CC}=5V$ ,**

CHARACTERISTICS	SYMBOL	TEST CONDITION	Min.	Typ.	Max.	Unit
<b>DEAD TIME CONTROL SECTION</b>						
INPUT THRESHOLD VOLTAGE	Vthdt	ZERO DUTY CYCLE		3.0	3.3	V
		MAX. DUTY CYCLE		0.1		
<b>ERROR AMP SECTION</b>						
CLOSE LOOP VOLTAGE GAIN		0.5V ~ 3.5V		65		dB
CROSS OVER POINT		0dB		320		KHZ
OPNEG BIAS VOLTAGE		OPNEG OPEN	2.38	2.45	2.52	V
<b>OUTPUT SECTION</b>						
OUTPUT SATURATION VOLTAGE	Vdssat	Id=200mA		1.1	1.3	V
DRAIN OFF-STATE CURRENT	Idoff	Vcc=Vd=Vs=0V		2	10	uA
RISING TIME	Tr			100	200	ns
FALLING TIME	Tf			50	200	ns
<b>PROTECTION SECTION</b>						
OVER VOLTAGE PROTECTION ( OVP )	V33		3.8	4.1	4.3	V
	V5		5.8	6.2	6.6	V
	V12		4.41	4.64	4.90	V
	PT		1.2	1.25	1.3	V
UNDER VOLTAGE PROTECTION ( UVP )	V33		1.78	1.98	2.18	V
	V5		2.70	3.00	3.30	V
	V12		2.11	2.37	2.63	V
UVP DISABLE VOLTAGE	PT		0.55	0.62	0.68	V
UVP DELAY TIME	Td.uvp		100	280	500	ms
<b>REMOTE ON/OFF SECTION</b>						
REM HIGH INPUT VOLTAGE	Vremh		2.0			V
REM LOW INPUT VOLTAGE	Vreml				0.8	V
REM PULL HIGH VOLTAGE	Vremo		2.0		5.25	V
REM DELAY TIME	Trem		30	36	42	ms
REM OFF DELAY TIME	Toff		3.5	4.5	5.5	ms
<b>POWER GOOD SECTION</b>						
DETECTING INPUT VOLTAGE	Vdet		0.55	0.62	0.68	V
PG OUTPUT PULL-UP RESISTOR	Rpup, pg			5		K $\Omega$
PG OUTPUT LOAD RESISTOR	Rpg		0.5	1	2	K $\Omega$
PG DELAY TIME			150	280	350	ms
OUTPUT SATURATION VOLTAGE	Vsat.pg	Ipg=10mA		0.2	0.4	V
<b>SOFT START SECTION</b>						
SINK CURRENT OF SS	Iss.sink			13		uA
SOURCE CURRENT OF SS	Iss.source			700		uA
<b>TOTAL DEVICE</b>						
STANDBY SUPPLY CURRENT	Icc			10	20	mA
<b>OSCILLATION SECTION</b>						
OSCILLATION FREQUENCY	Fosc	RT=120K	55	60	65	KHZ

## APPLICATION NOTE

### 1. Input impedance:

Pin No.	Pin Name	Input impedance
1	V33	47K
2	V5	73K
3	V12	47K
4	PT	24 K +4.6 K

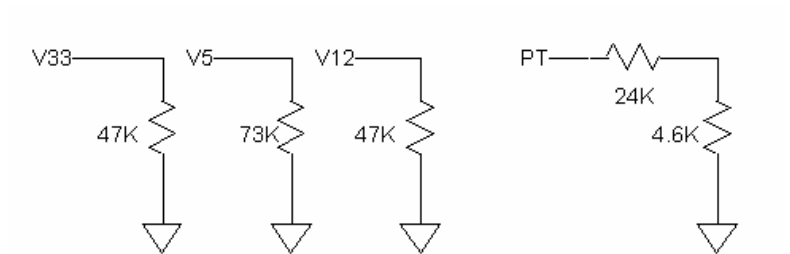

### 2. Sawtooth OSC. Function:

$$Q = CV = (KI) \times T \quad \leftarrow$$

$$\therefore C = 32.7 \times 10^{-12} \quad \leftarrow$$

$$V_{ref} = \text{Pin15 Voltage (typ. } \approx 2.5) \quad \leftarrow$$

$$K = 0.66(\text{CONSTANT}) \quad \leftarrow$$

$$V = V_{ref} \times \frac{35}{25} \approx 3.5(\text{typ.}) \dots (1) \quad \leftarrow$$

$$I = \frac{V_{ref}}{RT} \dots (2) \quad \leftarrow$$

$$\therefore T = \frac{CV}{KI} \quad \leftarrow$$

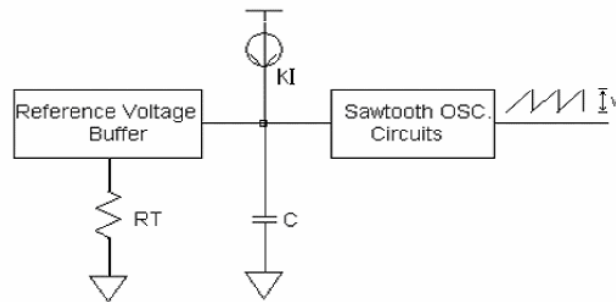

ex : RT resistor 107K  $V_{ref}=2.491$   $\leftarrow$

$$T = \frac{((32.7 \times 10^{-12}) \times 3.487)}{(0.66 \times (11.64 \times 10^{-6}))} \approx 14.84 \mu s \approx 67.4 \text{ KHZ}$$

(1)  $\leftarrow$

(2)  $\leftarrow$

### 3. REMOTE ON/OFF :

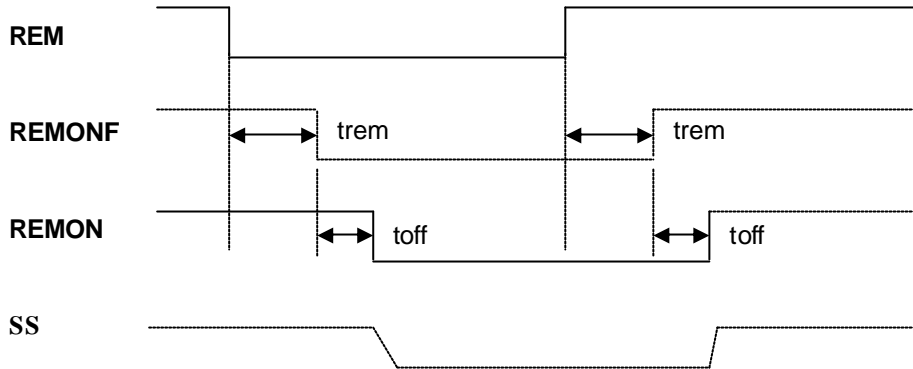

### 4. Under Voltage Protection Delay Time :

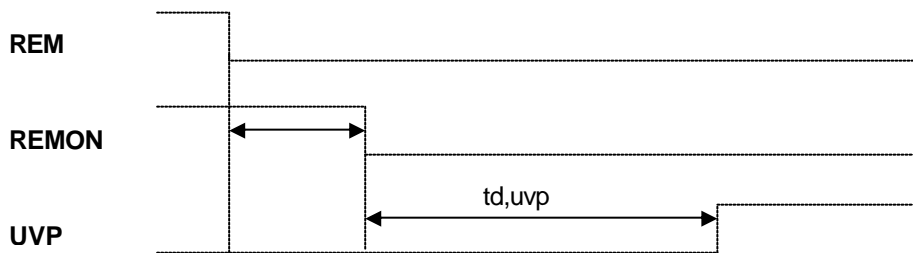

### 5. Pulse Width Modulation Block :

The output pulse width modulation is generated by comparison of the saw-tooth waveform from the capacitor  $C_T$  to the feedback of the voltage.

Therefore, an increase in feedback control signal amplitude cause a linear decrease of the output pulse width. Also, the SS(DTC and Soft-Start) limits the output pulse width. The timing diagram is shown as below:

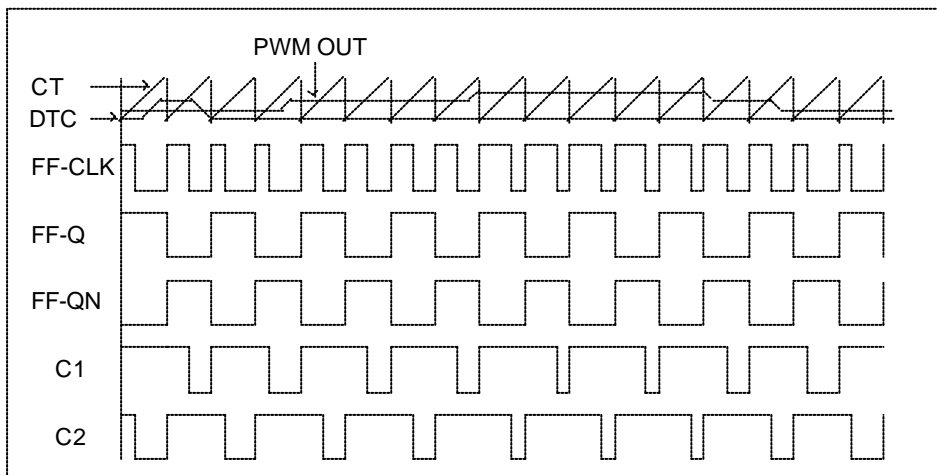

### 6. The function of “PT”:

This signal is prepared for extra OVP/OPP ( $V_{PT} > 1.25V$ ) or another Disable Under Voltage Protection function ( $V_{PT} < 0.62V$ )

### 7. Reference Application Circuit:

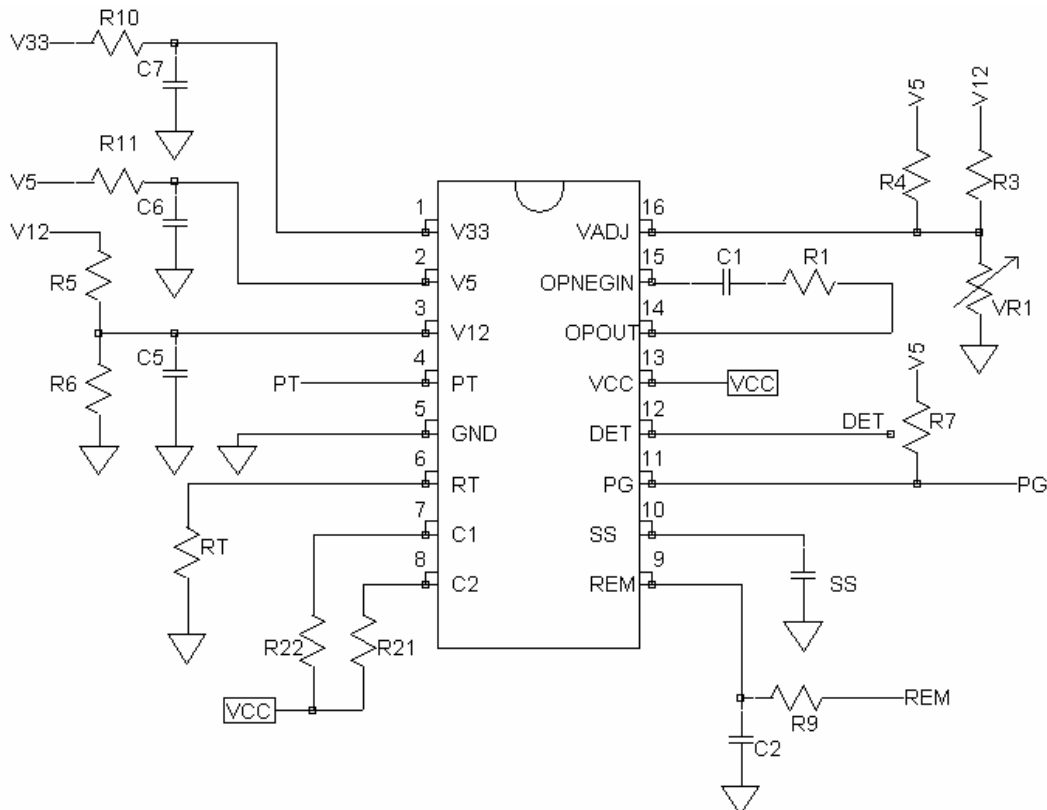

8. In some application power system, adding an external resistor (R9) could reduce the peak value spike from the environments to pin 9 (REM) and avoid pin 9 (REM) damaged by the external noise.

## MECHANICAL INFORMATION

### PLASTIC DUAL-IN-LINE PACKAGE

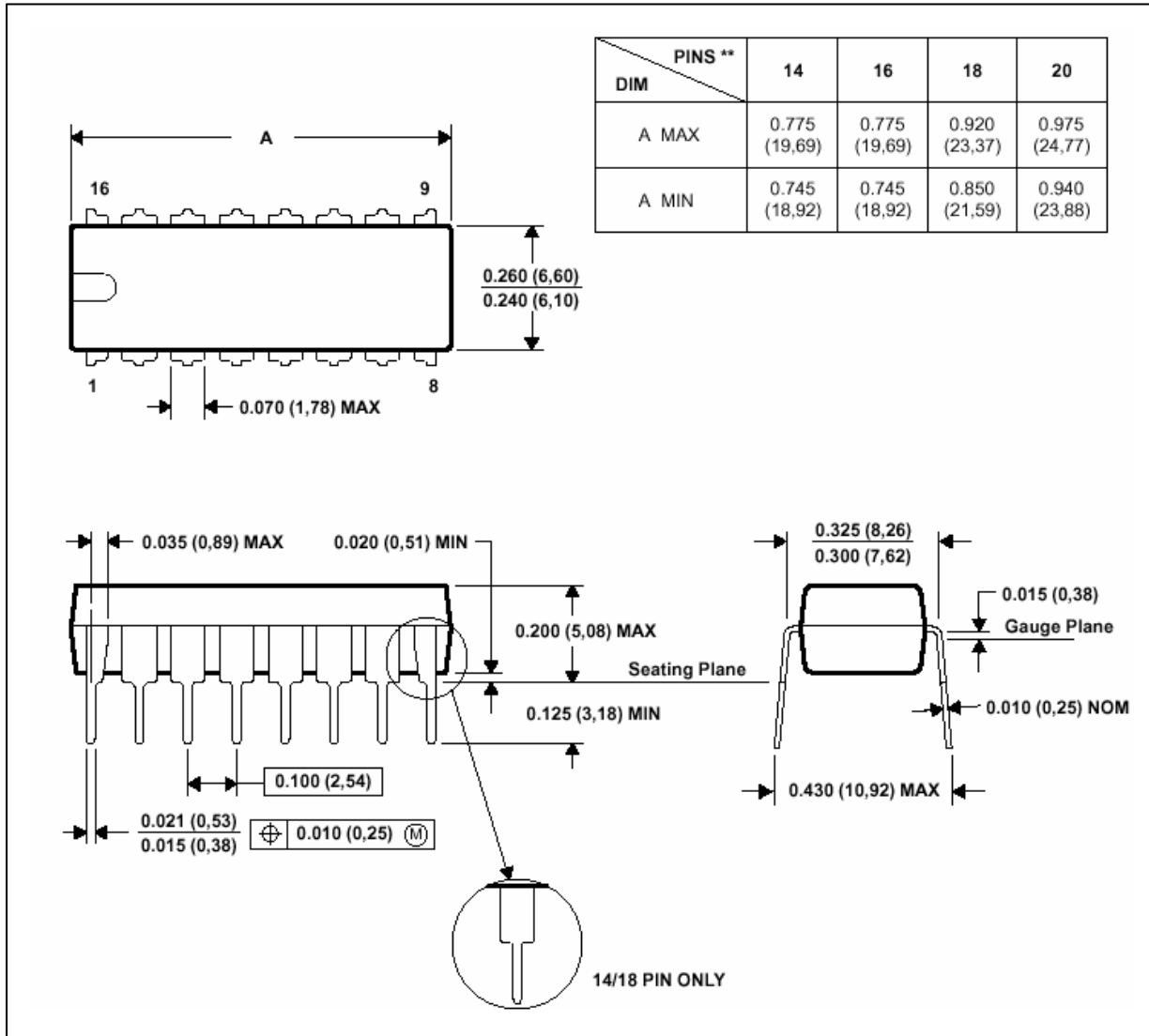

NOTE 1 : All linear dimensions are in inches ( millimeters ) .

NOTE 2 : This drawing is subject to change without notice.

NOTE 3 : Falls within JEDEC MS-001