

PWM Boost DC-DC Controller

Description

The FP6791 is a CMOS step-up switching controller incorporates a reference voltage circuit, an oscillator, an error amplifier, a PWM controller, an under voltage lockout circuit (UVLO) and a timer latch short-circuit protection circuit.

The switching frequency can be controlled by the resistor connected to the ROSC pin and the maximum duty ratio can be controlled by the resistor connected to the RDuty pin.

In addition, the FP6791 provides adjustable short-circuit protection delay time with an external capacitor connected to the CSP pin. If the maximum duty condition continues because of short-circuiting, the capacitor externally connected to the CSP pin is charged, and oscillation stops after a specific time. This condition is cleared by re-application of power. This controller IC allows various settings and employs a small package, making it very easy to use.

Pin Assignment

TSSOP Package (TSSOP-8)

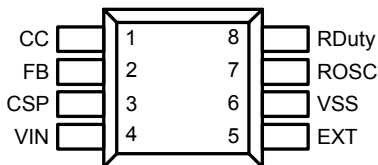

Figure 1. Pin Assignment of FP6791

Features

- Programmed Switching Frequency
- Programmed Maximum Duty Ratio
- Reference Voltage : 1.0V \pm 1.5%
- UVLO (Under-Voltage Lockout) Function :
 - Detection Voltage 2.2V
 - Hysteresis Width 0.3V
- Timer Latch Short-Circuit Protection Circuit : Delay Time Set by an External Capacitor.
- Internal Soft-Start Function
- External Compensation Network
- Small Package : 8-pin TSSOP
- RoHS Compliant

Applications

- LCD Panel
- Portable Equipments

Ordering Information

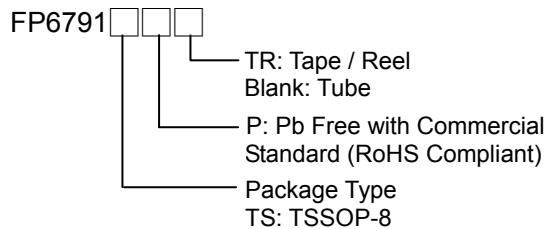

FITIPOWER DCC
CONTROL COPY

Typical Application Circuit

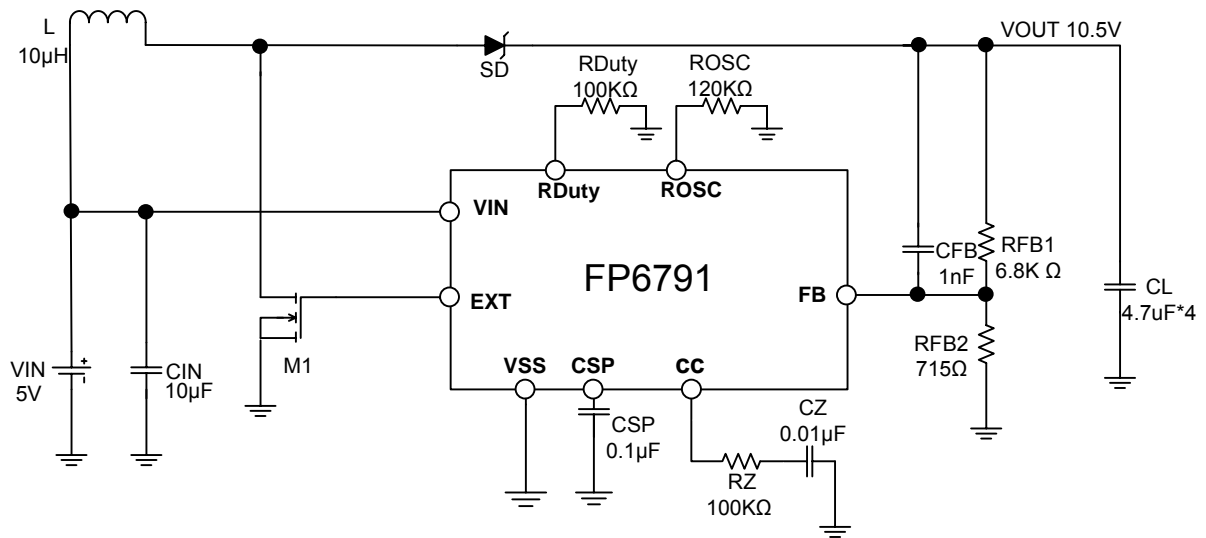

Figure 2. Typical Application Circuit of FP6791

Functional Pin Description

Pin Name	Pin Function
CC	Error amplifier circuit output and phase compensation pin
FB	Output voltage feedback pin
CSP	Short-circuit protection delay time setting pin
VIN	Power supply input pin
EXT	External transistor connection pin
VSS	GND pin
ROSC	Oscillation frequency setting resistor connection pin
RDuty	Maximum duty setting resistor connection pin

FITIPOWER DCG
CONTROL COPY

Block Diagram

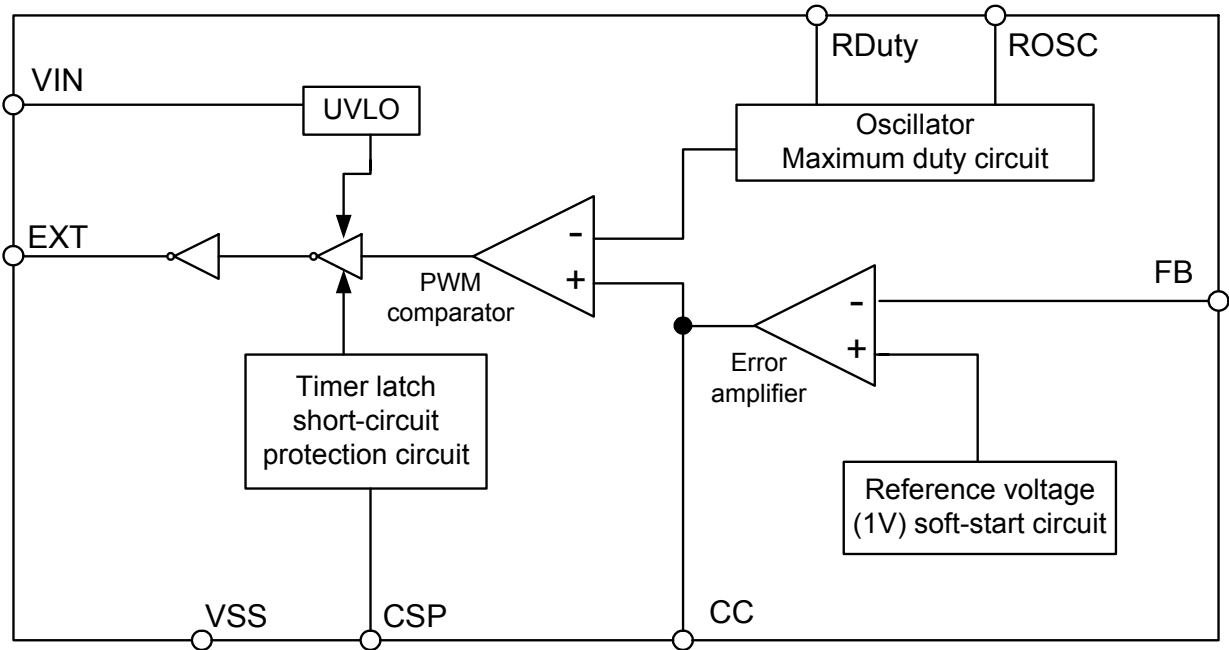

Figure 3. Block Diagram of FP6791

Absolute Maximum Ratings

- Supply Voltage (V_{IN})----- -0.3V to + 6.5V
- FB pin voltage (V_{FB})----- -0.3V to + 6.5V
- EXT pin voltage (V_{EXT})----- -0.3V to + 6.5V
- CSP pin voltage (V_{CSP})----- -0.3V to + 6.5V
- CC pin voltage (V_{CC})----- -0.3V to + 6.5V
- CC pin current (I_{CC})----- ±10mA
- ROSC pin voltage (V_{ROSC})----- -0.3V to + 6.5V
- ROSC pin current (I_{ROSC})----- ±10mA
- RDuty pin voltage (V_{RDuty})----- -0.3V to +6.5V
- RDuty pin current (I_{RDuty})----- ±10mA
- Storage temperature (T_{stg})----- -40 to + 125 °C
- Power dissipation (P_D), 8-Pin TSSOP----- 300mW

Note : Stresses beyond those listed under "Absolute Maximum Ratings" may cause permanent damage to the device.

Recommended Operating Conditions

- Supply Voltage (V_{IN})----- +2.6V to +6V
- Operation Temperature Range (T_{opr})----- -40°C to +85°C

Electrical Characteristics

$V_{IN}=+5V$, $T_A=25^{\circ}C$, unless otherwise specified. (Note.1)

Parameter	Symbol	Conditions	Min	Typ	Max	Unit
Operating Input Voltage	V_{IN}		2.6	5	6	V
FB Voltage	V_{FB}		0.985	1	1.015	V
Current Consumption ($V_{IN}=3.3V$)	I_{SS1}	$F_{osc} = 1.1MHz ; V_{FB} = 0.95V$	-	700	900	μA
EXT Pin Output Current($V_{IN}=3.3V$)	I_{EXT}	$V_{EXT}=V_{IN} - 0.4V$		100	-60	mA
	I_{EXT}	$V_{EXT}= 0.4V$	100	160		
FB Voltage Temperature Coefficient	$\Delta V_{FB} / \Delta T_a$	$T_a = -40^{\circ}C$ to $+85^{\circ}C$		100		ppm/ $^{\circ}C$
Oscillation Frequency	F_{OSC}	$R_{osc}=120K\Omega$	1.02	1.133	1.246	MHz
Oscillation Frequency Temperature Coefficient	$\Delta F_{OSC} / \Delta T_a$	$T_a = -40^{\circ}C$ to $+85^{\circ}C$ $F_{osc} = 1.1MHz$		500		ppm/ $^{\circ}C$
Maximum Duty Cycle	MaxDuty	$R_{Duty}=100K\Omega$	80.6	84.9	94	%
Soft-Start Time	t_{ss}		15	20	30	ms
UVLO Detection Voltage	V_{UVLO}		2.09	2.2	2.31	V
UVLO Hysteresis Width	$V_{UVLOHYS}$		0.18	0.3	0.42	V
Short-circuit protection delay time	T_{PRO}	$CSP=0.1\mu F$	33	50	75	ms
CC Pin Output Current	I_{CCH}	$V_{FB} =2V$		50		μA
	I_{CCH}	$V_{FB} =0V$		-50		
Timer Latch Reset Voltage	V_{RTL}		0.7	1	1.3	V

Note 1 : Specifications are production tested at $T_A=25^{\circ}C$. Specifications over the $-40^{\circ}C$ to $85^{\circ}C$ operating temperature range are guaranteed by design.

FITIPOWER DCC
CONTROL COPY

Typical Performance Curves

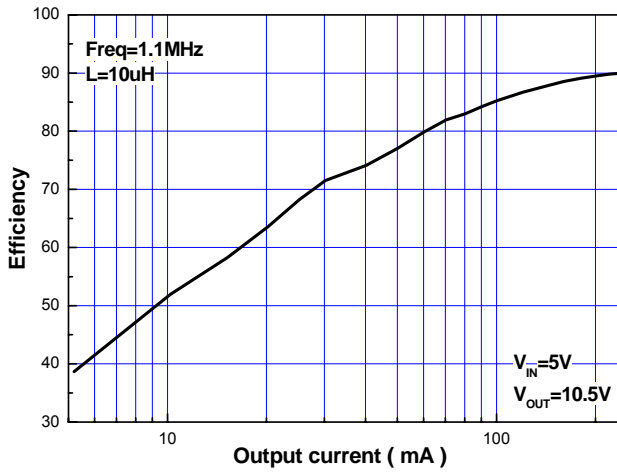

Figure 1. Efficiency vs. Output Current

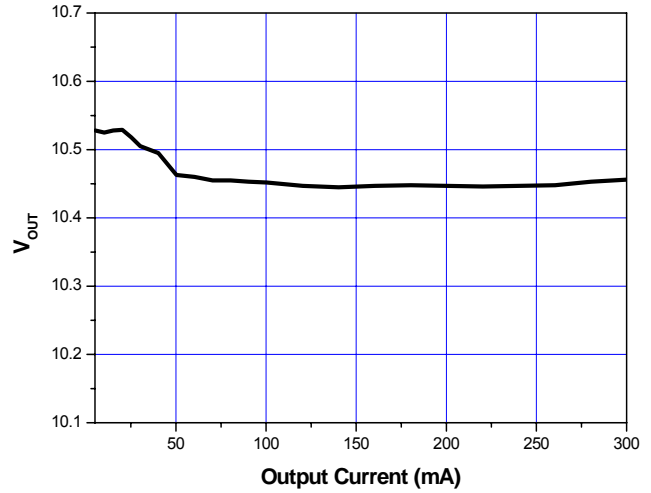

Figure 2. Output Voltage vs. Output Current

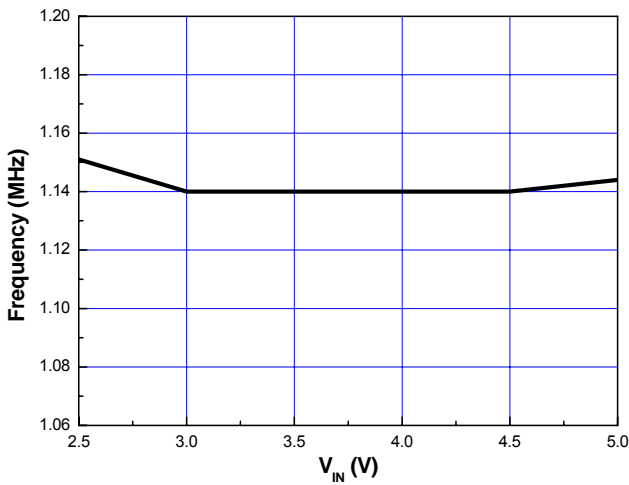

Figure 3. Frequency vs. Input Voltage

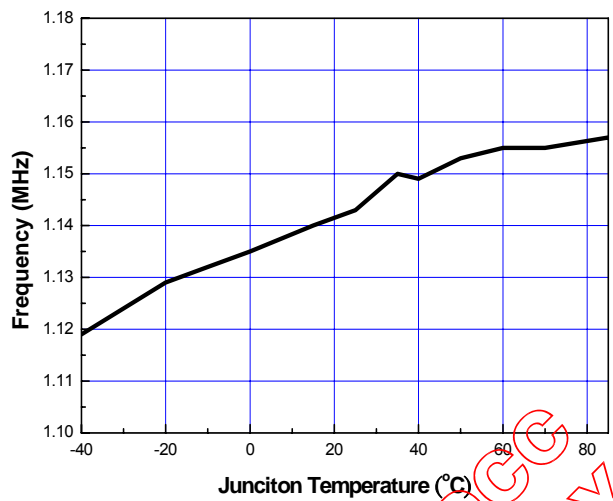

Figure 4. Frequency vs. Junction Temperature

FITIPOWER DGC CONTROL COPY

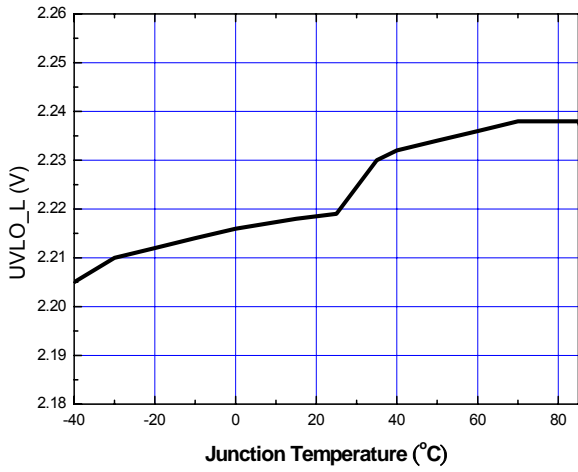

Figure 5. UVLO Low Level vs. Junction Temperature

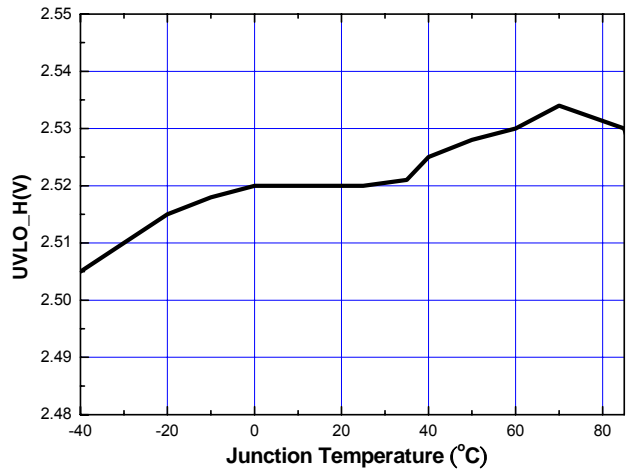

Figure 6. UVLO High Level vs. Junction Temperature

Typical Performance Curves (Continued)

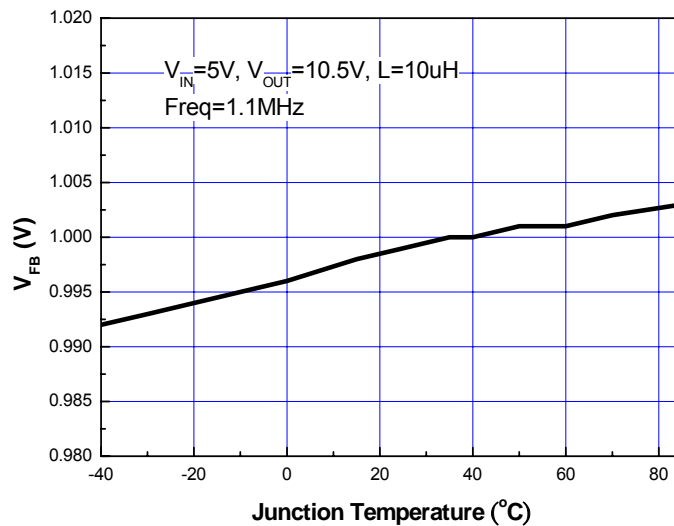
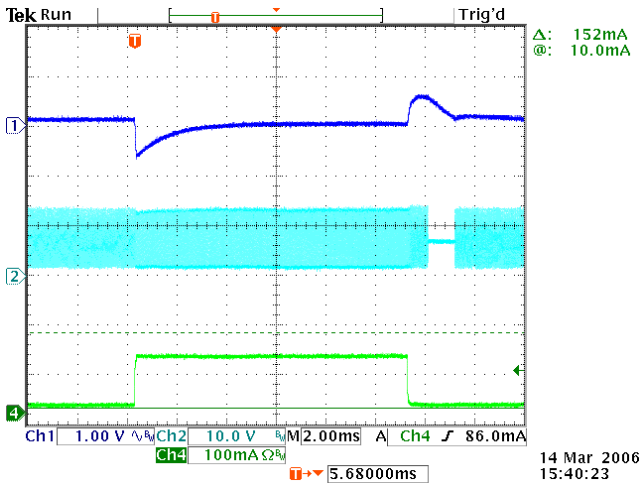

Figure 7. VFB vs. Junction Temperature

FITIPOWER DCC
CONTROL COPY



CH1: Output Voltage, AC-Coupled
 CH2: Switch Point
 CH4: Loading Current
 $V_{IN}=5V$, $V_{OUT}=10.5V$, I_{LOAD} form 1mA to 100mA,
 $L=10\mu H$, $FREQ=1.1MHz$, $C_{OUT}=4.7\mu F*4+0.1\mu F*2$

Figure 8. Load transient Response

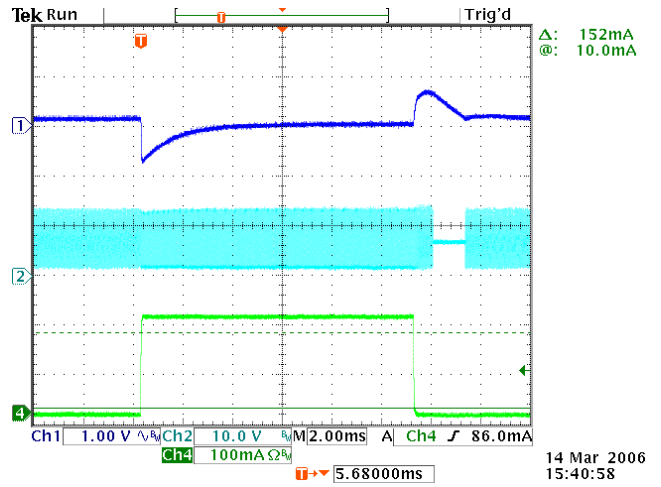

CH1: Output Voltage, AC-Coupled
 CH2: Switch Point
 CH4: Loading Current
 $V_{IN}=5V$, $V_{OUT}=10.5V$, I_{LOAD} form 1mA to 200mA,
 $L=10\mu H$, $FREQ=1.1MHz$, $C_{OUT}=4.7\mu F*4+0.1\mu F*2$

Figure 9. Load transient Response

Typical Performance Curves (Continued)

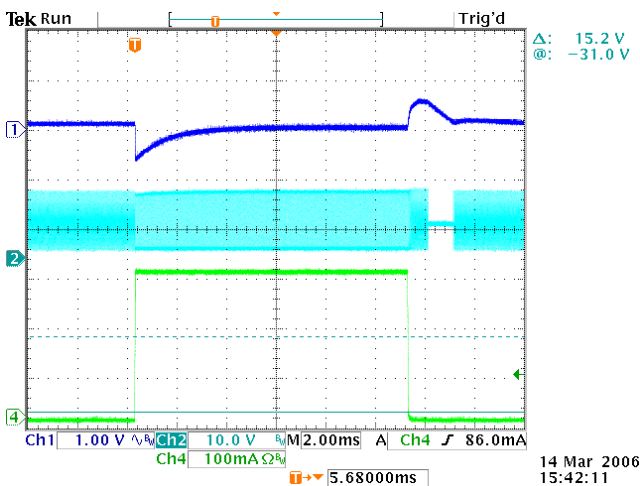

CH1: Output Voltage, AC-Coupled

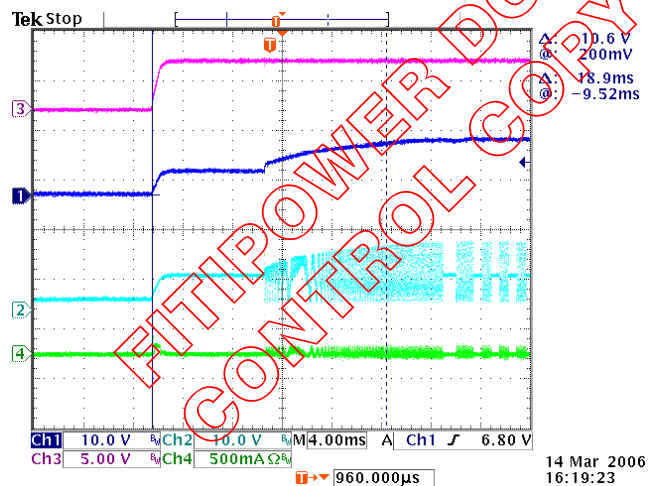

CH1: Output Voltage

CH2: Switch Point
 CH4: Loading Current
 $V_{IN}=5V$, $V_{OUT}=10.5V$, I_{LOAD} form 1mA to 300mA,
 $L=10\mu H$, $FREQ=1.1MHz$, $C_{OUT}=4.7\mu F*4+0.1\mu F*2$

CH2: Switch Point
 CH3: VIN
 CH4: Inductor Current
 $V_{IN}=5V$, $V_{OUT}=10.5V$, $L=10\mu H$, $I_{LOAD}=0mA$,
 $FREQ=1.1MHz$, $C_{OUT}=4.7\mu F*4+0.1\mu F*2$

Figure 10. Load transient Response

Figure 11. Light Load Start-up Waveform

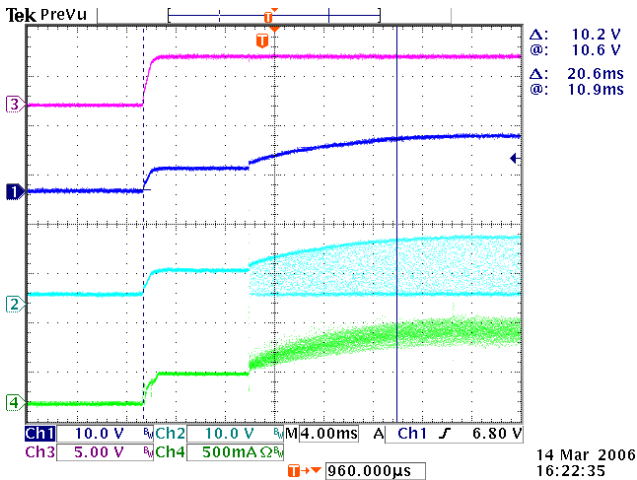

CH1: Output Voltage
 CH2: Switch Point
 CH3: VIN
 CH4: Inductor Current
 $V_{IN}=5V$, $V_{OUT}=10.5V$, $L=10\mu H$, $FREQ=1.1MHz$, $I_{LOAD}=300mA$, $C_{OUT}=4.7\mu F*4+0.1\mu F*2$

Figure 12. Heavy Load Start-up Waveform

Outline Information

TSSOP-8 Package (Unit: mm)

FITIPOWER DCC
CONTROL COPY

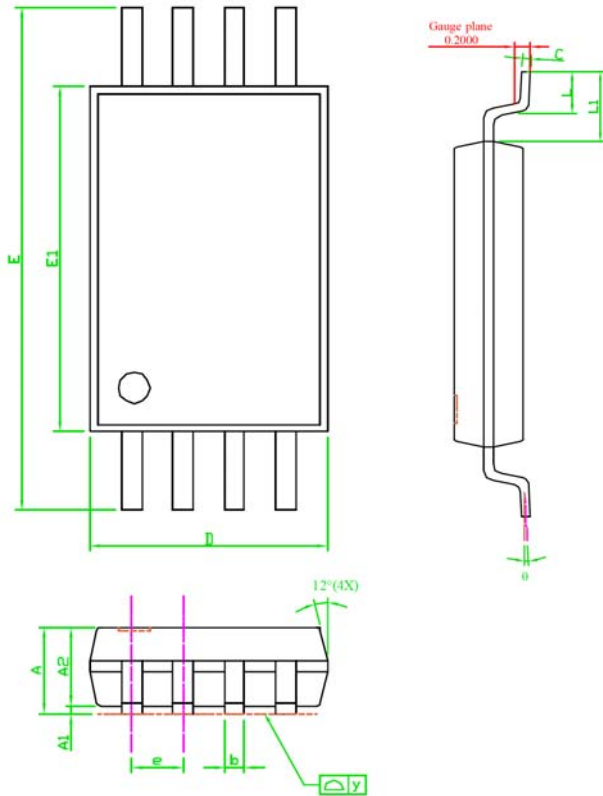

SYMBOLS UNIT	DIMENSION IN MILLIMETER		
	MIN	NOM	MAX
A	---	---	1.20
A1	0.05	---	0.15
A2	0.80	1.00	1.05
b	0.19	---	0.30
C	0.09	---	0.20
D	2.90	3.00	3.10
E	6.20	6.40	6.60
E1	4.30	4.40	4.50
e	---	0.65	---
L	0.45	0.60	0.75
y	---	---	0.10
θ	0°	---	8°
L1	0.90	1.00	1.10

- Note 1 : Package Body Sizes Exclude Mold Flash and Protrusions or Gate Burrs.
- Note 2 : Tolerance ±0.1 mm Unless Otherwise Specified.
- Note 3 : Coplanarity : 0.1mm
- Note 4 : Controlling Dimension Is Millimeter. Converted Inch Dimensions Are Not necessarily Exact.
- Note 5 : Followed from JEDEC MO-153.

FITIPOWER DCG
CONTROL COPY

Life Support Policy

Fitipower's products are not authorized for use as critical components in life support devices or other medical systems.