

Low-Noise Boost DC-DC Converter

Description

The FP6795 is a step-up current mode PWM DC/DC converter with an internal 2A, 0.16Ω N-channel MOSFET. Pin selectable fixed switching frequency (1.2MHz or 640KHz) and external compensation pin provide the user flexibility in setting the loop dynamic, allowing the use of tiny, low profile inductors and low value, low ESR ceramic output capacitors.

The FP6795 provides soft-start feature which is programmable with an external capacitor. In shutdown mode, current consumption is reduced to only 0.1uA. The FP6795 converts the input voltage ranged from 2.6V to 5.5V into an output voltage up to 16V.

FP6795 is available in the space-saving MSOP-8 package.

Features

- Operating Voltage from 2.6V to 5.5V
- Output Voltage from Input Voltage to 16V
- 90% Efficiency
- 2A, 0.16Ω Internal Power MOSFET
- Pin Selectable Switching Frequency (1.2MHz or 640KHz)
- Programmed Soft Start
- External Compensation Network
- 0.1uA Shutdown Current
- MSOP-8 Package
- RoHS Compliant

Applications

- LCD Displays
- Portable Applications
- Hand-Held Devices
- Digital Cameras

Pin Assignments

MS Package (MSOP-8)

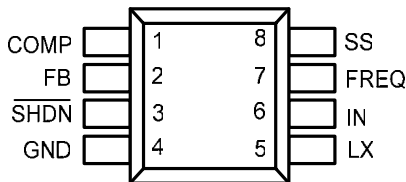

MP Package (MSOP- 8<Exposed Pad>)

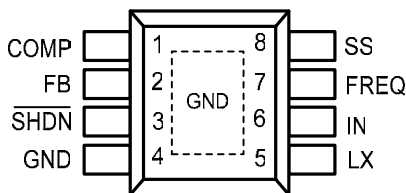
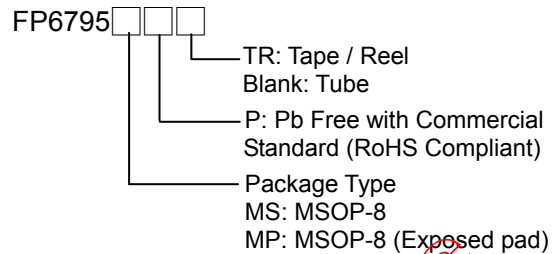

Figure 1. Pin Assignment of FP6795 (Top View)

Ordering Information



FITIPOWER DCC CONTROL COPY

Typical Application Circuit

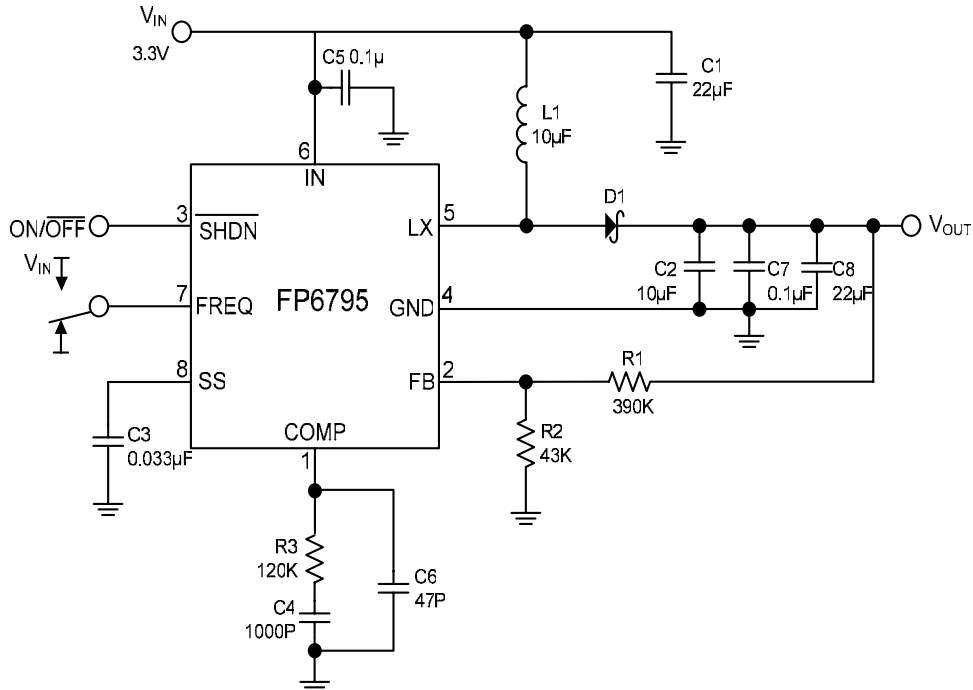

Figure 2. Typical Application Circuit of FP6795

V _{IN} (V)	V _{OUT} (V)	f _{OSC} (KHz)	L (µH)	C _{OUT} (µF)	R ₃ (kΩ)	C ₄ (pF)	C ₆ (pF)	I _{OUT} (MAX) (mA)
3.3	12.5	640	10 (TDK SLF7045)	33 (Ceramic)	120	1000	47	300
3.3	12.5	1200	6.8 (TDK SLF7045)	33 (Ceramic)	200	680	33	300

Functional Pin Description

Pin Name	Pin Function
COMP	Compensation Pin for Error Amplifier. Connect a series RC from COMP to ground.
FB	Feedback Pin. The typical reference voltage is 1.24V. Set $V_{OUT} = 1.24V (1 + R1/R2)$. See Figure 2.
SHDN	Enable Pin. Connect SHDN low to turn off FP6795.
GND	Ground.
LX	Switching Pin.
IN	Power Input Pin.
FREQ	Frequency Select Pin. When FREQ connected to ground, the frequency is 640KHz. When FREQ connected to V _{IN} , the frequency is 1.2MHz.
SS	Soft-Start Control Pin. Connect a capacitor (C3) to this pin. The pin will source 4uA constant current to charge the capacitor. Leaving floating for not using soft-start.

Block Diagram

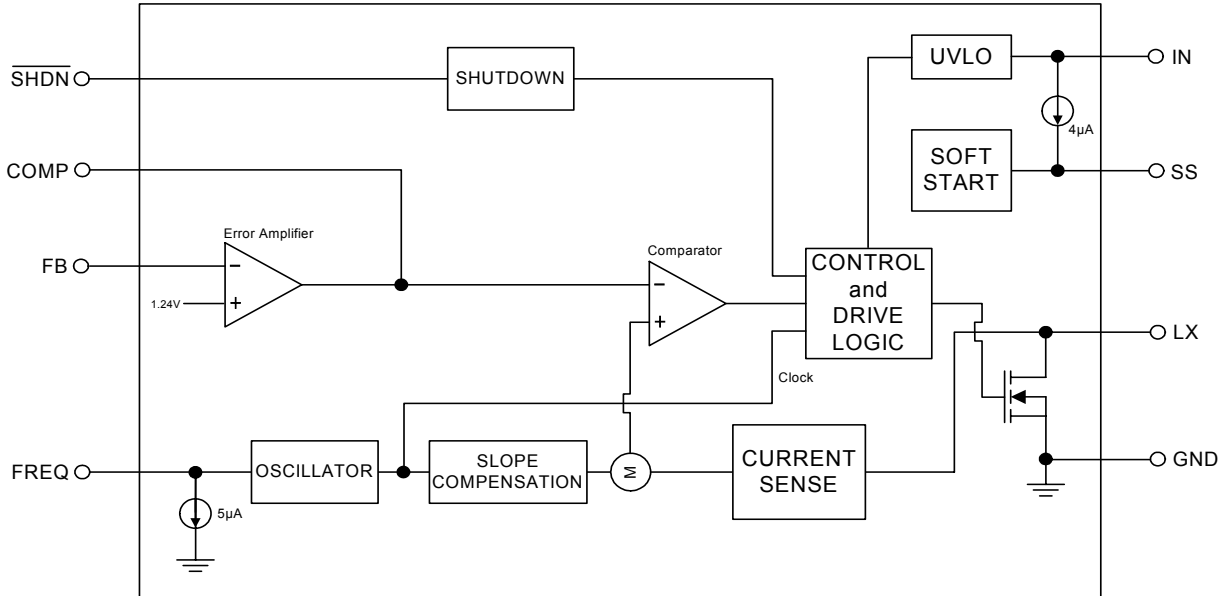

Figure 3. Block Diagram of FP6795

Absolute Maximum Ratings

- VIN to GND----- - 0.3V to + 6V
- LX to GND----- - 0.3V to + 18V
- SHDN, FB, SS, FREQ, COMP to GND----- - 0.3V to + 6V
- Power Dissipation:
 - MSOP-8 (P_D)----- 340mw (T_A=70°C)
 - MSOP-8<Exposed Pad> (P_D)----- 500mw (T_A=70°C)
- Package Thermal Resistance:
 - MSOP-8 (θ_{JA})----- +160°C/W
 - MSOP-8<Exposed Pad> (θ_{JA})----- +110°C/W
- Junction Temperature----- + 150°C
- Storage Temperature Range----- - 65°C to + 150°C
- Lead Temperature (Soldering, 10sec.)----- 260°C

Note : Stresses beyond those listed under “Absolute Maximum Ratings” may cause permanent damage to the device.

Recommended Operating Conditions

- Supply Voltage, V_{IN}----- 3.3V±10%, 5V±10%
- Output Voltage (Max.)----- 16V
- Operation Temperature Range----- - 40°C to + 85°C

Electrical Characteristics

($V_{IN}=3V$, $\overline{SHDN}=3V$, $FREQ=GND$, $T_A=25^\circ C$, unless otherwise specified)

Parameter	Symbol	Test Conditions	Min	Typ	Max	Units
INPUT						
Operation Voltage Range	V_{IN}		2.6		5.5	V
V_{IN} Under Voltage Lockout	UVLO	V_{IN} rising, typical hysteresis is 100mV	2.25	2.38	2.52	V
Quiescent Current	I_{IN}	$V_{FB}=1.3V$, not switching		160	350	μA
		$V_{FB}=1V$, switching		0.8	5	mA
Shutdown Current	I_{SD}	$\overline{SHDN}=0V$		0.1	10	μA
ERROR AMPLIFIER						
Feedback Voltage	V_{FB}		1.227	1.24	1.253	V
FB Input Bias Current	I_{FB}	$V_{FB}=1.24V$		0	150	nA
Feedback Voltage Line Regulation		$2.6V < V_{IN} < 5.5V$		0.08	0.3	%/V
Transconductance	gm	$\Delta I = 5\mu A$	70	170	240	μS
Voltage Gain	A_V			700		V/V
OSCILLATOR						
Frequency	F_{OSC}	FREQ=GND	540	640	740	KHz
		FREQ= V_{IN}	1000	1200	1500	KHz
Maximum Duty Cycle	T_{DUTY}	FREQ=GND		90		%
		FREQ= V_{IN}		90		%
N-CHANNEL SWITCH						
Current Limit	I_{LIM}		1.5	2	2.5	A
On-Resistance	R_{ON}	$I_{LX}=200mA$		0.16	0.35	Ω
Leakage Current	I_{LXOFF}	$V_{LX}=16V$		0.01	30	μA
SOFT-START						
Reset Switching Resistance					100	Ω
Charge Current	I_{SS}	$V_{SS}=1.2V$	1.5	4	7	μA
CONTROL INPUTS						
Input High Level	V_{IH}	\overline{SHDN} , FREQ	$0.7 \cdot V_{IN}$			V
Input Low Level	V_{IL}	\overline{SHDN} , FREQ			$0.3 \cdot V_{IN}$	V
Hysteresis		\overline{SHDN} , FREQ		$0.1 \cdot V_{IN}$		V
Frequency Pulldown Current	I_{FREQ}		1.8	5	9	μA
\overline{SHDN} Input Current	I_{SHDN}			0.001	1	μA
PROTECTION						
Thermal Shutdown	T_{SD}			160		$^\circ C$
Thermal Shutdown Hysteresis	ΔT_{SD}			25		$^\circ C$

Typical Performance Curves

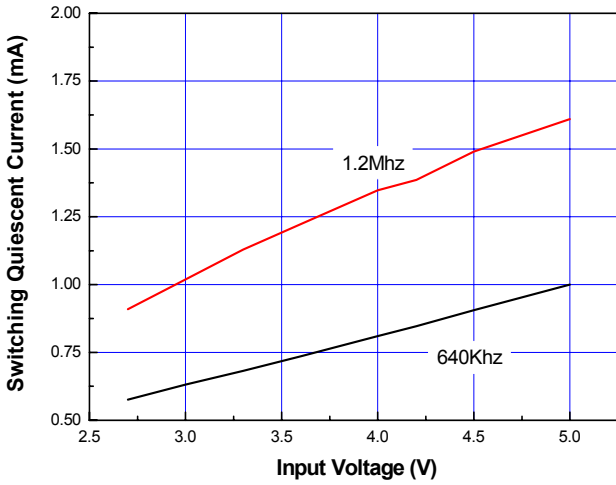

Figure 4. Switching Quiescent Current vs. Input Voltage

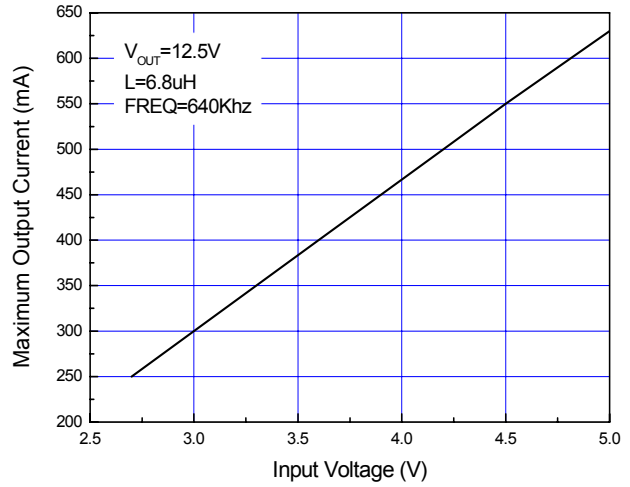

Figure 5. Maximum Output Current vs. Input Voltage

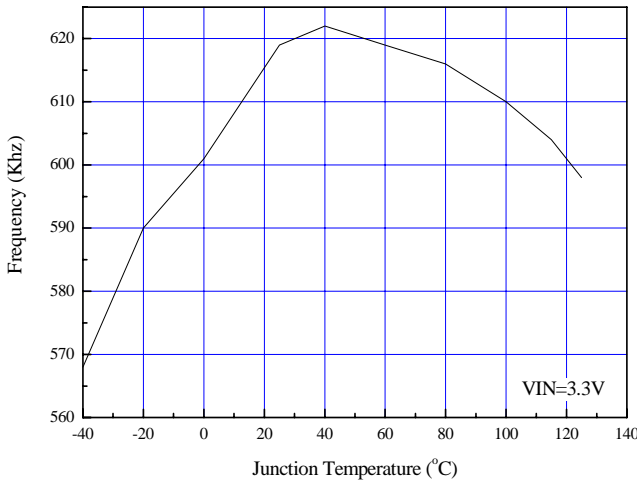

Figure 6. Frequency vs. Junction Temperature

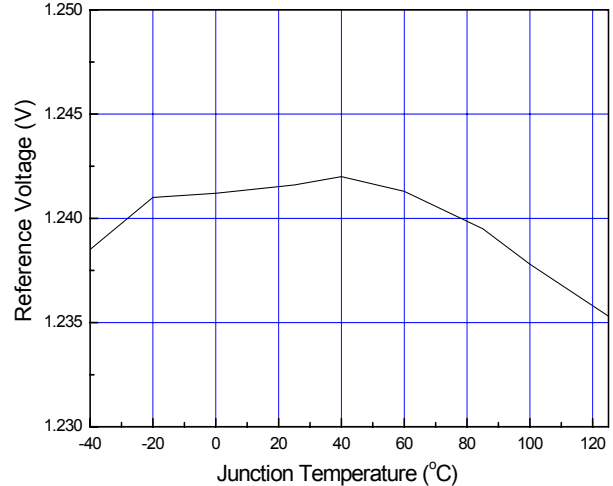

Figure 7. Reference Voltage vs. Junction Temperature

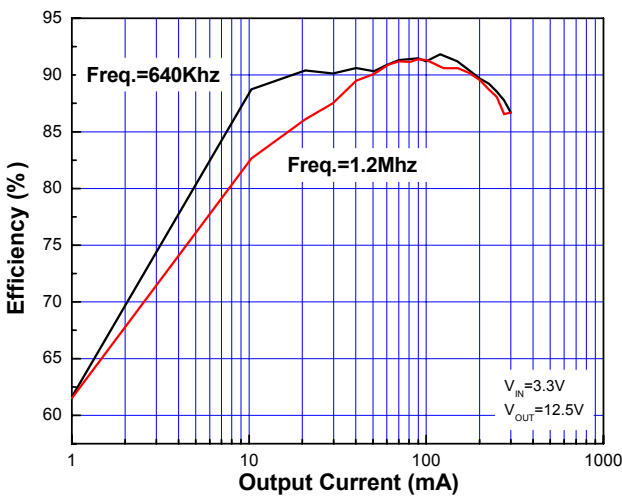

Figure 8. Efficiency vs. Output Current

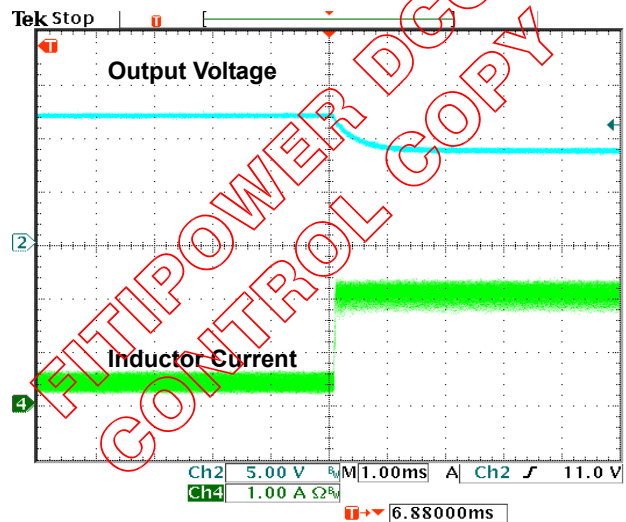
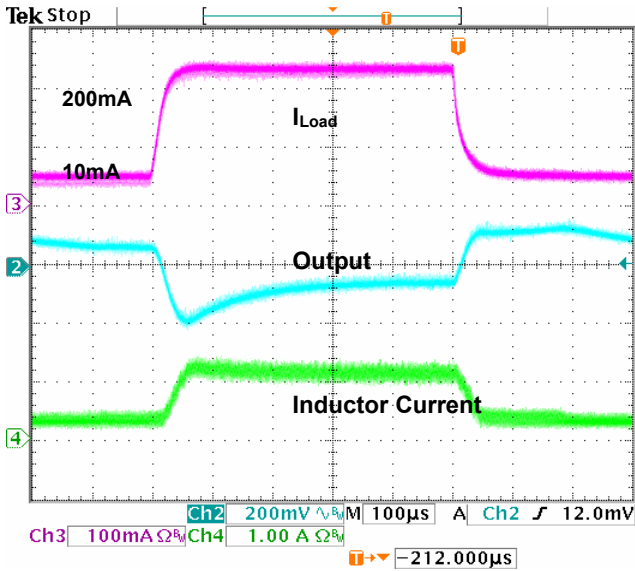

Figure 9. OCP Waveform

Typical Performance Curves (Continued)



$V_{IN}=3.3V, V_{OUT}=12.5V, FREQ=640KHz, C_{OUT}=33\mu F$

Figure 10. Load transient Response

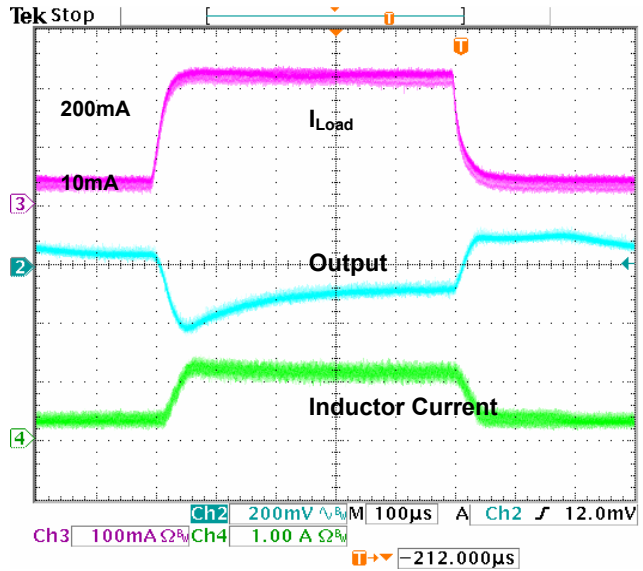

$V_{IN}=3.3V, V_{OUT}=12.5V, FREQ=1.2MHz, C_{OUT}=33\mu F$

Figure 11. Load transient Response

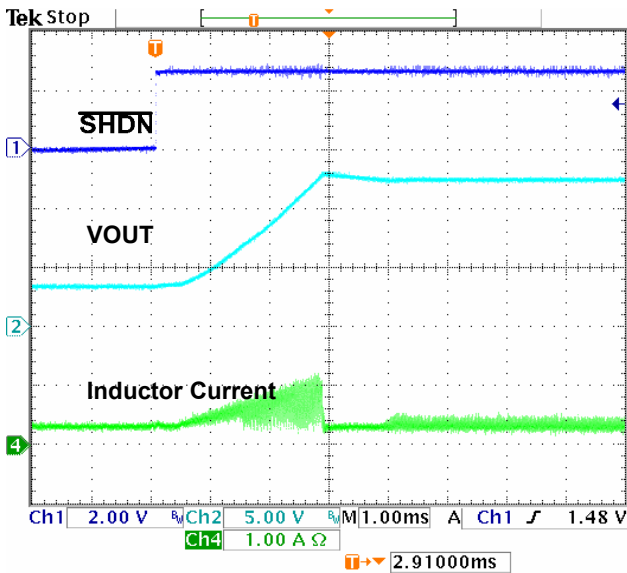

$V_{IN}=3.3V, V_{OUT}=12.5V, I_{OUT}=10mA, L=10\mu H, C_3=33nF, FREQ=640KHz, C_{OUT}=33\mu F$

Figure 12. Start-up Waveform with Soft-start

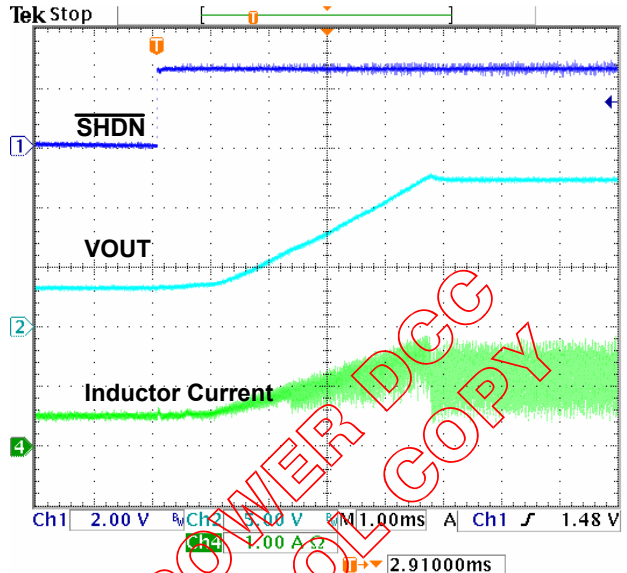

$V_{IN}=3.3V, V_{OUT}=12.5V, I_{OUT}=200mA, L=10\mu H, C_3=33nF, FREQ=640KHz, C_{OUT}=33\mu F$

Figure 13. Start-up Waveform with Soft-start

Typical Performance Curves (Continued)

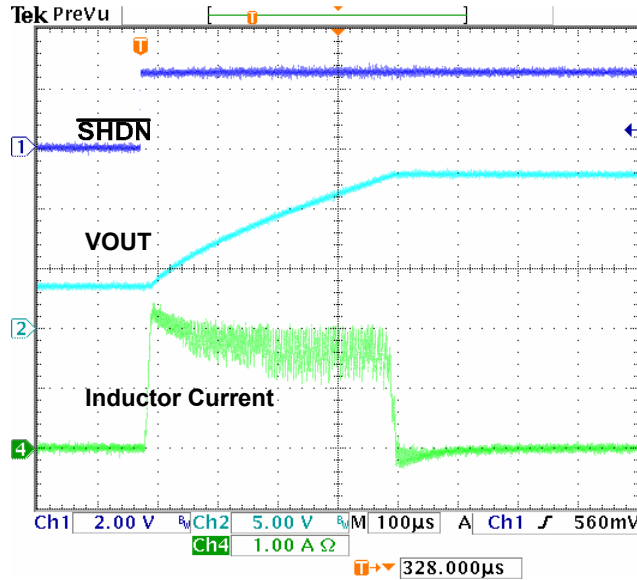

$V_{IN}=3.3V, V_{OUT}=12.5V, I_{OUT}=10mA, L=10\mu H, C3=33nF,$
 $FREQ=640KHz, C_{OUT}=33\mu F,$

Figure 14. Start-up Waveform without Soft-start

Outline Information

MSOP- 8 Package (Unit: mm)

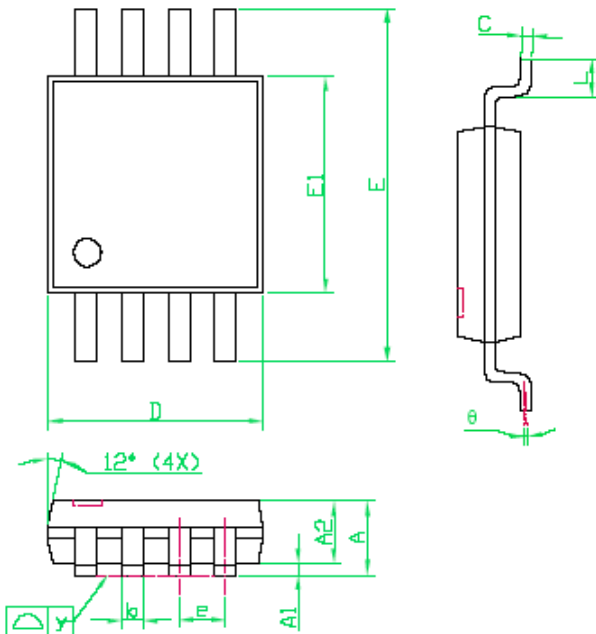

SYMBOLS UNIT	DIMENSION IN MILLIMETER		
	MIN	NOM	MAX
A	0.81	1.02	1.12
A1	0.05	---	0.15
A2	0.76	0.86	0.97
b	0.28	0.30	0.38
C	0.13	0.15	0.23
D	2.90	3.00	3.10
E	4.70	4.90	5.10
E1	2.90	3.00	3.10
e	---	0.65	---
L	0.40	0.53	0.66
y	---	---	0.10
θ	0°	---	6°

Note 1 : Package Body Sizes Exclude Mold Flash and Gate Burrs.

Note 2 : Dimension L Is Measured in Gage Plane.

Note 3 : Tolerance 0.10 mm Unless Otherwise Specified.

Note 4 : Controlling Dimension Is Millimeter Converted Inch Dimensions Are Not necessarily Exact.

Note 5 : Design Following JEDEC MO-187.

Outline Information (Continued)

MSOP- 8(Exposed Pad)Package (Unit: mm)

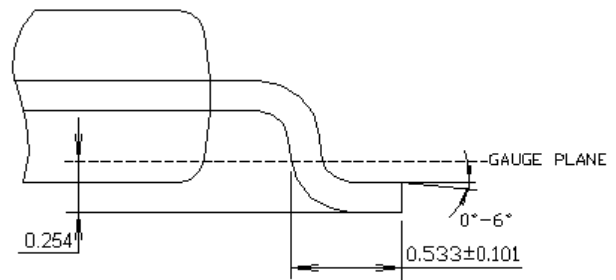
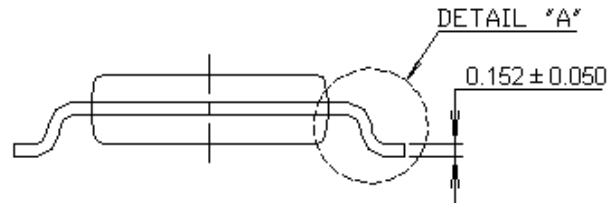
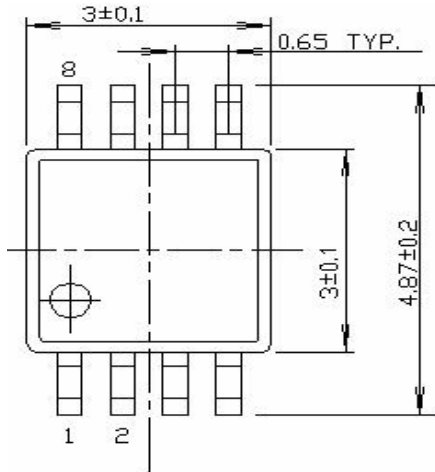

DETAIL "A"

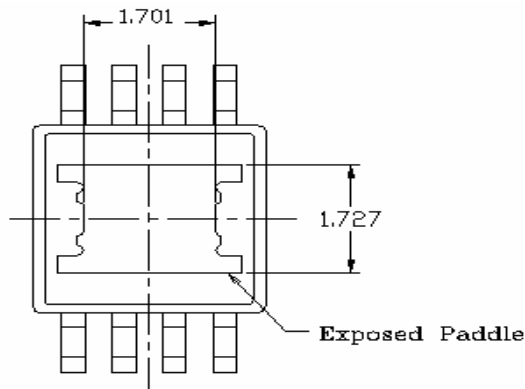

Bottom View

- Note 1 : All Dimension Are In Millimeter
- Note 2 : Package Length Does Not Include Mold Flash, Protrusions Or Gate Burr.
- Note 3 : Package Width Does Not Include Interlead Flash Or Protrusions.

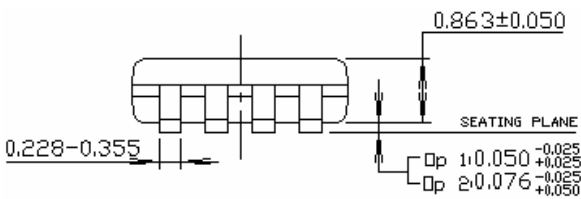

FITIPOWER DCG
CONTROL COPY

Life Support Policy

Fitipower's products are not authorized for use as critical components in life support devices or other medical systems.