

Microprocessor Voltage Monitors with Manual Reset

Description

The FP6811 and FP6812 are cost-effective system supervisory circuits designed to monitor the power supply status in microprocessor (μ P) and digital systems. In addition, they provide a de-bounced manual reset input pin to initiate a reset.

These circuits assert a reset signal whenever the V_{CC} supply voltage declines below a preset threshold, keeping it asserted for at least 140ms after V_{CC} has risen above the reset threshold.

The FP6811-N has an open-drain output stage, while FP6811-C and FP6812-C have push-pull outputs. The FP6811-N's open-drain output requires a pull-up resistor. The FP6811 has an active-low $\overline{\text{RESET}}$ output while the FP6812 has an active-high RESET output.

The FP6811 and FP6812 are optimized to reject fast transient glitches on the V_{CC} line. A low supply current makes these devices suitable for portable equipment. Each device is available in a 4-pin SC-70-4 package format.

Pin Assignments

C4 Package (SC-70-4)

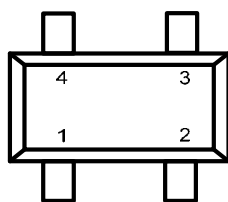

TOP VIEW
 1. GND
 2. $\overline{\text{RESET}}$ / RESET
 3. $\overline{\text{MR}}$
 4. V_{CC}

Figure 1. Pin Assignments of FP6811 / FP6812

Features

- Precision Monitoring of 2.5V, 3.0V, 3.3V, and 5.0V Power-Supply Voltages
- 140ms Guaranteed Minimum Reset Output Duration
- Low Supply Current
- V_{CC} Transient Immunity
- Small SC-70-4 Package
- No External Components
- Guaranteed Reset Valid to $V_{CC}=1V$
- Available in Three Output Configurations
 - Open-Drain $\overline{\text{RESET}}$ Output (FP6811-N)
 - Push-Pull $\overline{\text{RESET}}$ Output (FP6811-C)
 - Push-Pull RESET Output (FP6812-C)
- RoHS Compliant

Applications

- Computers
- Battery Powered Equipments
- Microprocessor Power Supply Monitoring
- Embedded Systems
- Automotive

Ordering Information

FP6811/12-

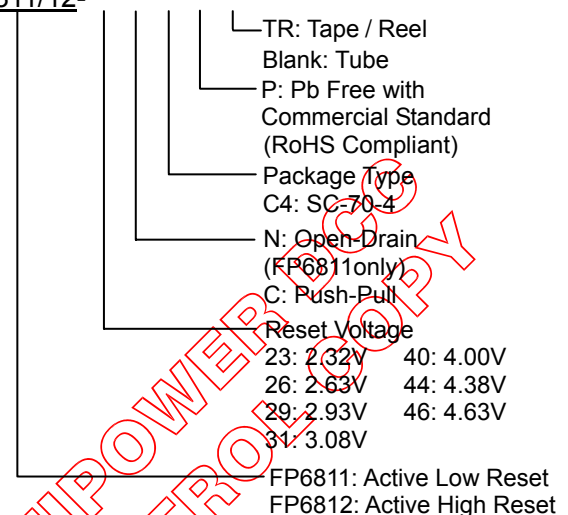

Note: Please consult Fitipower sales office or authorized distributors for availability of special reset voltages.

SC-70-4 Marking (FP6811)

Part Number	Product Code	Part Number	Product Code
FP6811-23NC4P	Ka	FP6811-23CC4P	Km
FP6811-26NC4P	Kb	FP6811-26CC4P	Kn
FP6811-29NC4P	Kd	FP6811-29CC4P	Kr
FP6811-31NC4P	Ke	FP6811-31CC4P	Ks
FP6811-40NC4P	Kf	FP6811-40CC4P	Kt
FP6811-44NC4P	Kh	FP6811-44CC4P	Ku
FP6811-46NC4P	Ki	FP6811-46CC4P	Kv

SC-70-4 Marking (FP6812)

Part Number	Product Code	Part Number	Product Code
FP6812-23CC4P	CL	FP6812-40CC4P	CR
FP6812-26CC4P	CM	FP6812-44CC4P	CS
FP6812-29CC4P	CN	FP6812-46CC4P	CT
FP6812-31CC4P	CP		

Typical Application Circuit

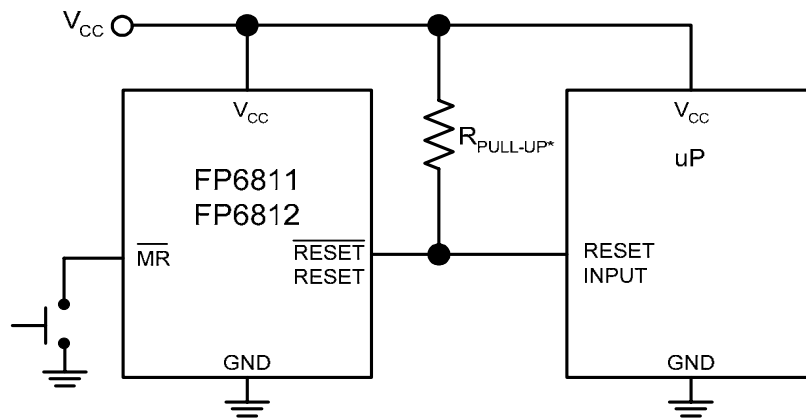

*FP6811-N ONLY

Figure 2. Typical Application Circuit of FP6811/FP6812

Functional Pin Description

Pin Name	Pin Function
GND	Ground
$\overline{\text{RESET}}$ (FP6811)	$\overline{\text{RESET}}$ Output remains low while V_{CC} is below the reset threshold or while $\overline{\text{MR}}$ is held low, and for at least 140ms after V_{CC} rises above the reset threshold.
RESET (FP6812)	RESET Output remains high while V_{CC} is below the reset threshold or while $\overline{\text{MR}}$ is held low, and for at least 140ms after V_{CC} rises above the reset threshold.
$\overline{\text{MR}}$	Manual Reset Input. Driving low to force a reset. Reset remains active as long as $\overline{\text{MR}}$ is low and for the reset timeout period after $\overline{\text{MR}}$ is released. $\overline{\text{MR}}$ has an internal 63 k pull up resistor to VCC.
V_{CC}	Supply Voltage

Block Diagram

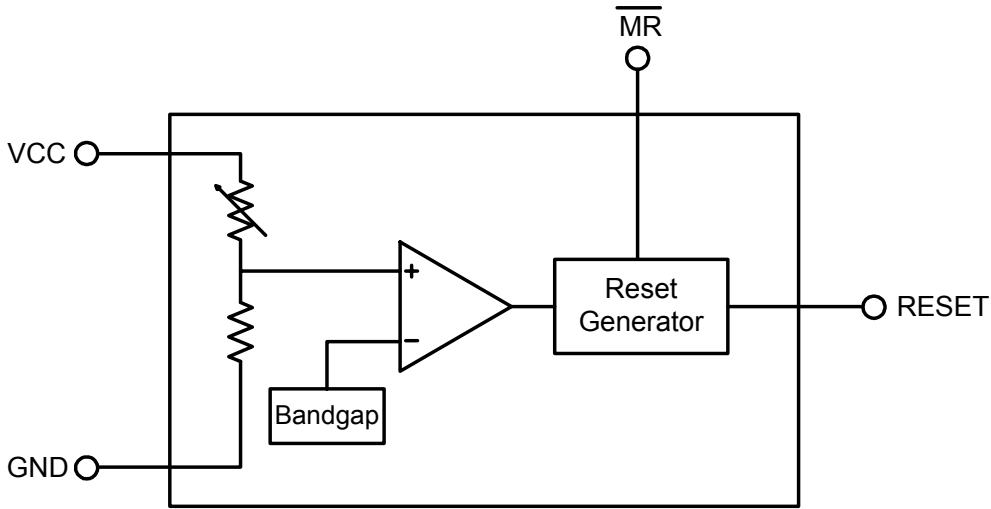

Figure 3. Block Diagram of FP6811/FP6812

Absolute Maximum Ratings

- Supply Voltage (V_{CC} to GND) ----- -0.3V to +6V
- RESET, \overline{RESET} Voltage (Push-Pull) ----- -0.3 to ($V_{CC}+0.3V$)
- \overline{RESET} Voltage (Open Drain) ----- -0.3V to ($V_{CC}+0.3V$)
- Input Current (V_{CC}) ----- 20mA
- Output Current, RESET, \overline{RESET} ----- 20mA
- Rate of Rise (V_{CC}) ----- 100V/us
- Power Dissipation @ $T_A=70^\circ C$, SC-70-4 (P_D) ----- 110mW
- Package Thermal Resistance, SC-70-4 (θ_{JA}) ----- 500°C/W
- Junction Temperature (T_J) ----- 150°C
- Storage Temperature (T_S) ----- -65°C to +150°C
- Lead Temperature (Soldering, 10sec) ----- 260°C

Note : Stresses beyond those listed under "Absolute Maximum Ratings" may cause permanent damage to the device.

Recommended Operating Conditions

- Supply Voltage (V_{CC} to GND) ----- +1.0V to +5.5V
- Operation Temperature Range ----- -40°C to +85°C



Electrical Characteristics

(V_{CC}=full range, T_A=25°C, unless otherwise specified.)

Parameter	Symbol	Conditions	Min	Typ.	Max	Unit
V _{CC} Range	V _{CC}		1.0		5.5	V
Supply Current	I _{CC}	V _{CC} <5.5V, FP68__-46/44/40		3		μA
		V _{CC} <3.6V, FP68__-23/26/29/31		3		
Reset Threshold	V _{TH}	FP6811-46/ FP6812-46	4.54	4.63	4.72	V
		FP6811-44/ FP6812-44	4.29	4.38	4.47	
		FP6811-40/ FP6812-40	3.92	4.00	4.08	
		FP6811-31/ FP6812-31	3.02	3.08	3.14	
		FP6811-29/ FP6812-29	2.87	2.93	2.99	
		FP6811-26/ FP6812-26	2.58	2.63	2.68	
Reset Threshold Tempco				30		ppm/°C
$\overline{\text{MR}}$ Input Threshold	V _{IH}	V _{CC} > V _{TH(MAX)} , V _{CC} = 3V	2.3			V
	V _{IL}				0.8	
	V _{IH}	V _{CC} > V _{TH(MAX)} , V _{CC} < 3V	0.7V _{CC}			
	V _{IL}				0.25V _{CC}	
$\overline{\text{MR}}$ Glitch Immunity				100		ns
V _{CC} to Reset Delay		V _{CC} =V _{TH} to (V _{th} -100mV)		20		us
Reset Active Timeout Period			140	240	560	ms
$\overline{\text{RESET}}$ Output Voltage Low (Push-Pull active low and Open-Drain active low, FP6811)	V _{OL}	V _{CC} =V _{TH} min, I _{SINK} =1.2mA, FP6811-23/26/29/31			0.3	V
		V _{CC} =V _{TH} min, I _{SINK} =3.2mA, FP6811-44/46			0.4	
		V _{CC} >1.0V, I _{SINK} =50uA			0.3	
RESET Output Voltage Low (push-pull active high, FP6812)	V _{OL}	V _{CC} =V _{TH} max, I _{SINK} =1.2mA, FP6811-23/26/29/31			0.3	V
		V _{CC} =V _{TH} max, I _{SINK} =3.2mA, FP6811-44/46			0.4	V
$\overline{\text{RESET}}$ Output Voltage High (push-pull active low, FP6811)	V _{OH}	V _{CC} >V _{TH} max, I _{SOURCE} =500uA, FP6811-23/26/29/31	0.8V _{CC}			V
		V _{CC} >V _{TH} max, I _{SOURCE} =800uA, FP6811-44/46	V _{CC} -1.5			V
RESET Output Voltage High (push-pull active high, FP6812)	V _{OH}	1.8V<V _{CC} <V _{TH} min, I _{SOURCE} =150uA	0.8V _{CC}			V
$\overline{\text{RESET}}$ Open-Drain Output Leakage Current (FP6811-N)		V _{CC} >V _{TH} , RESET de-asserted			1	μA

FITIPOWER DCC CONTROL COPY

Typical Performance Curves

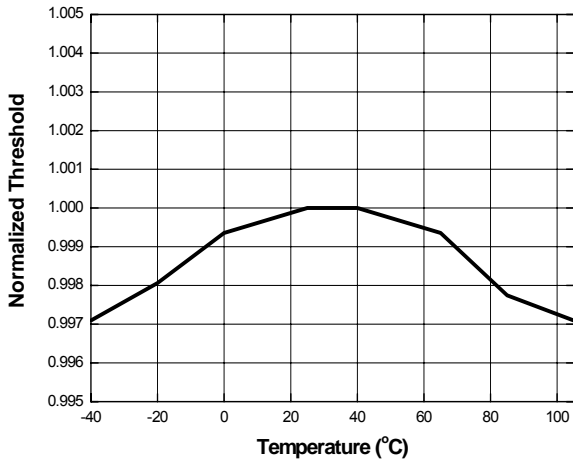

Figure 4. Normalized Reset Threshold vs. Temperature

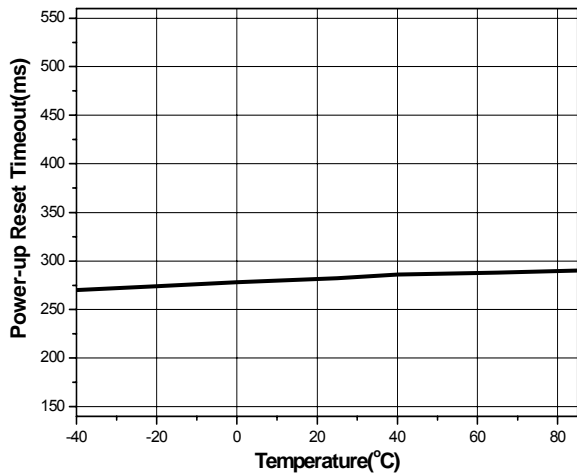

Figure 5. Power-up Timeout vs. Temperature

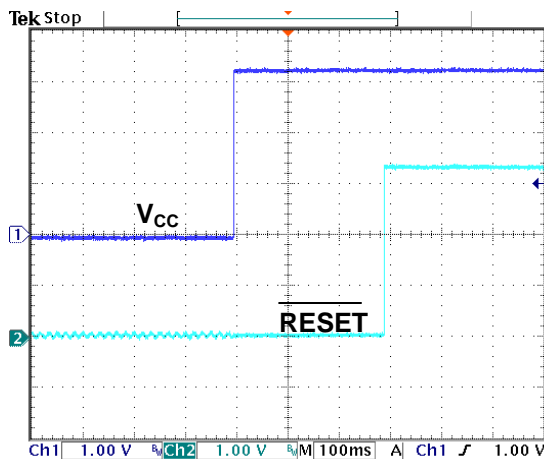

Figure 6. Power-Up $\overline{\text{RESET}}$ Timeout Waveforms;

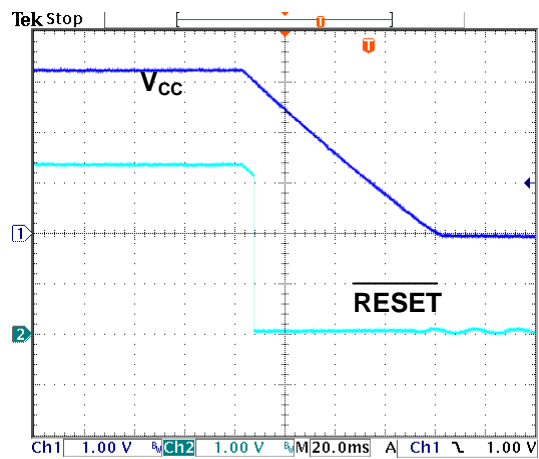

Figure 7. Power-Down $\overline{\text{RESET}}$ Delay Waveforms;

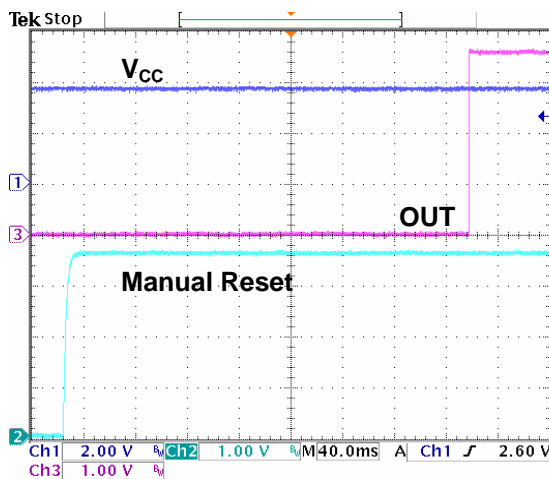

Figure 8. Manual Reset Voltage On Waveform for $-V_{TH}=3.1V$

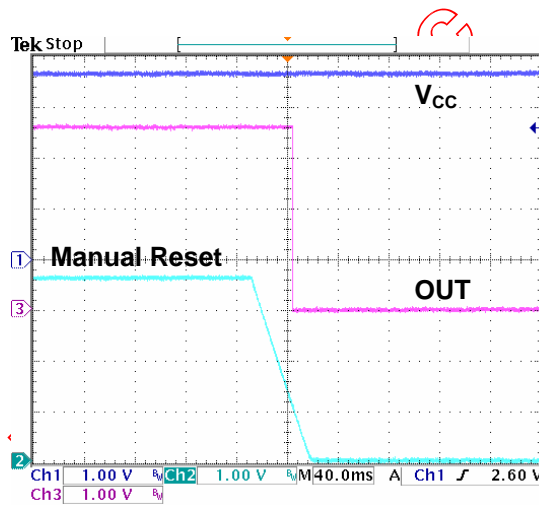

Figure 9. Manual Reset Voltage Off Waveform for $-V_{TH}=3.1V$

Typical Performance Curves (Continued)

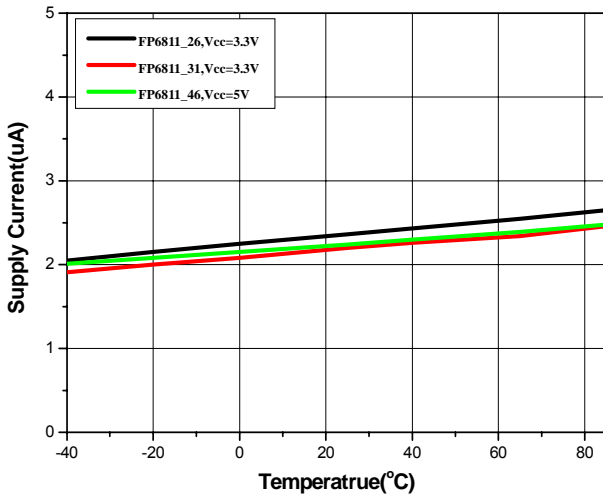

Figure 10. Supply Current vs. Temperature

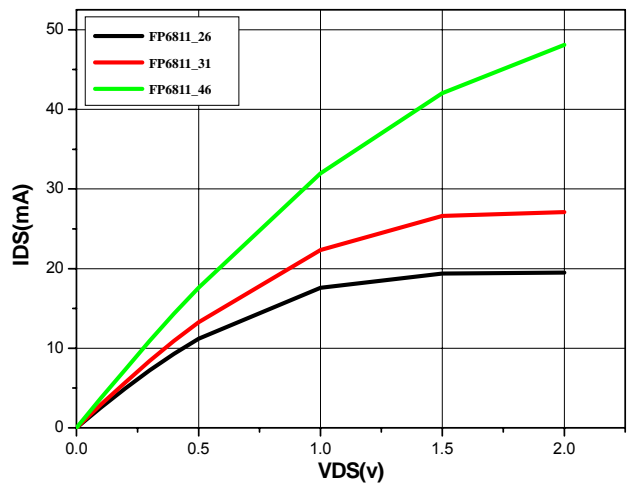

Figure 11. Output Sinking Capability

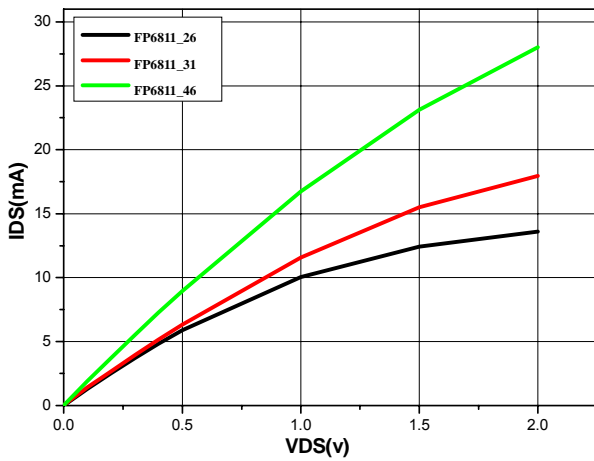
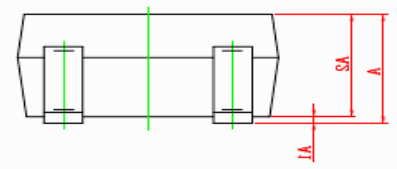
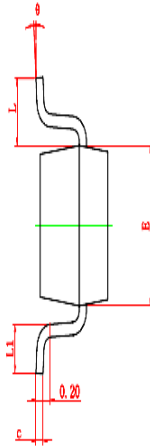
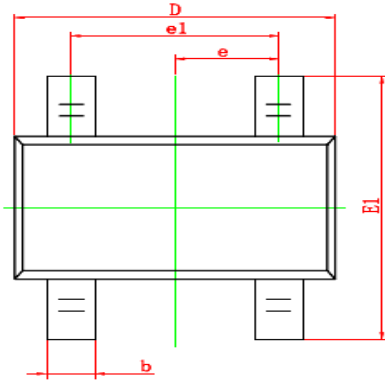

Figure 12. Output Sourcing Capability

FITIPOWER DCC
CONTROL COPY

Outline Information

SC-70-4 Package (Unit: mm)



SYMBOLS UNIT	DIMENSION IN MILLIMETER		
	MIN	NOM	MAX
A	0.90	---	1.10
A1	0.00	---	0.10
A2	0.90	---	1.00
b	0.15	---	0.35
c	0.08	---	0.15
D	2.00	---	2.20
E	1.15	1.25	1.15
E1	2.15	---	2.45
e	---	0.65TYP	---
e1	1.20	---	1.40
L	---	0.525REF	---
L1	0.26	---	0.46
θ	- 15°		

Note 1 : Package Body Sizes Exclude Mold Flash and Gate Burrs.

Note 2 : Tolerance ± 0.10 mm(4 mil) Unless Otherwise Specified.

Note 3 : Controlling Dimension Is Millimeter. Converted Inch Dimension Are Not Necessarily Exact.

Note 4 : Followed from EIAJ ED-7500-2.

Note 5 : Dimension L Is measured Form 0.1 mm above Seated Plane.

FITIPOWER DCC
CONTROL COPY

Life Support Policy

Fitipower's products are not authorized for use as critical components in life support devices or other medical systems.