

Boost PWM Controller for White LED Driver

Description

FP6738 is a high efficiency DC/DC boost controller for series connection white LED driver, resulting in uniform brightness. Small external parts and external driving MOSFET make FP6738 ideal and flexible for designing low cost and high efficiency white LED display backlights.

FP6738 operates using Pulse Width Modulation (PWM) to produce a regulated output. The ISEN pin is available to sense output current. At COMP pin, using compensation capacitor can stabilize voltage loop and prove minimize in-rush current during start-up. FP6738 has both over-voltage and over-temperature protection functions.

FP6738 is available in space-saving 8-pin TDFN and SOP packages.

Features

- 250KHz Switching Frequency
- V_{IN} Operation Range : 2.5V to 5.5V
- 0.2V LED Current Sense Voltage
- PWM or Analog Dimming Control
- Over-Voltage Protection and Over-Temperature Protection
- Low Shutdown Current at 0.1 μ A
- Small External Inductor and Capacitors
- 8-Pin TDFN and SOP Packages
- RoHS Compliant

Applications

- Car TVs
- Portable DVDs
- PDA
- GPS
- Color Display Backlights

Pin Assignments

SO Package (SOP-8)

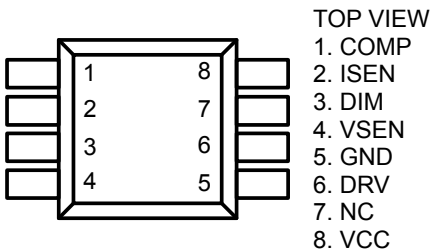

WD Package (TDFN-8) (2mm x 2mm)

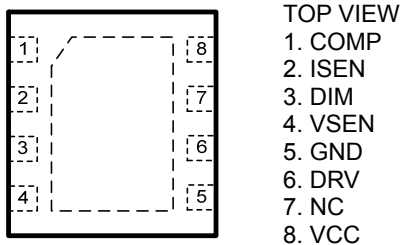
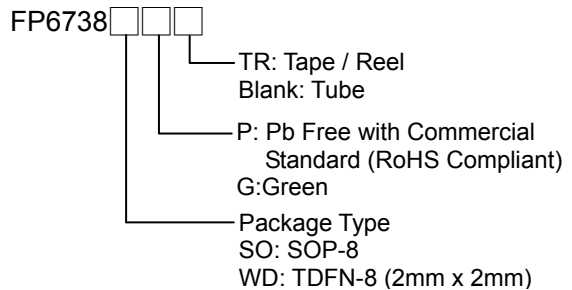

Figure 1. Pin Assignment of FP6738

Ordering Information



TDFN-8 (2mm x 2mm) Marking

Part Number	Product Code
FP6738WDP	C6P

FITIPOWER DCC
CONTROL COPY

Typical Application Circuit

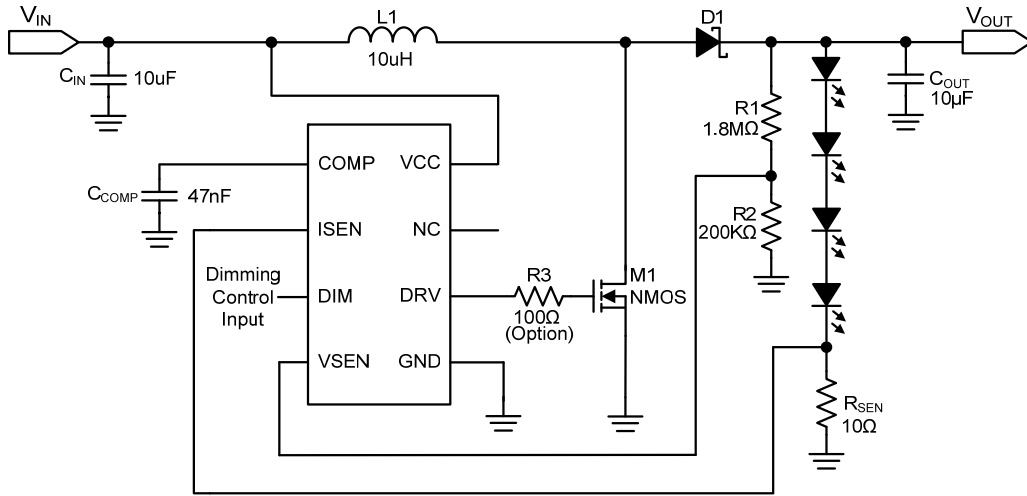

Figure 2. Typical Application Circuit of FP6738

Functional Pin Description

Pin Name	Pin Function
COMP	Soft start and voltage loop compensation
ISEN	Load current sensing
DIM	Shut down and dimming control. 1. Analog dimming control : apply 0.8V to 1.3V DC voltage signal 2. Digital dimming control : apply external PWM pulse signal
VSEN	Over-voltage protection setting pin
GND	Ground. Should be tied to a ground plane for best performance.
DRV	Driver output for external NMOS switch
VCC	Input supply pin.

Block Diagram

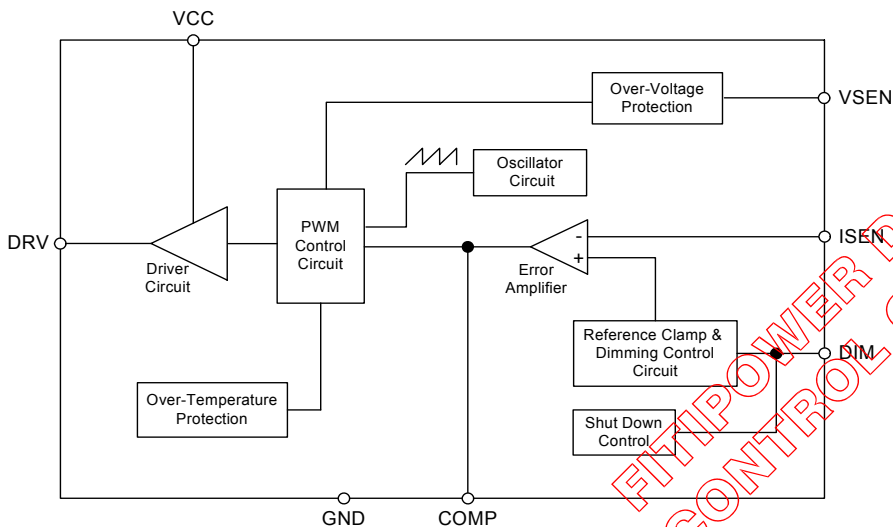

Figure 3. Block Diagram of FP6738

Absolute Maximum Ratings

- V_{CC} to GND----- +6V
- All Other Pins to GND----- +6V
- Junction Temperature (T_J)----- +150°C
- Storage Temperature Range (T_S)----- -65°C to +150°C
- Power Dissipation ($P_D, T_A=25^\circ\text{C}$):
 - SOP-8 (P_D) ----- +0.63W
 - TDFN-8(P_D)----- +1.25W
- Package Thermal Resistance, (θ_{JA}):
 - SOP-8 ----- +160°C/W
 - TDFN-8 (θ_{JA}) ----- +80°C/W
- Lead Temperature (Soldering, 10 sec.) ----- +260°C

Note : Stresses beyond those listed under "Absolute Maximum Ratings" may cause permanent damage to the device.

Recommended Operating Conditions

- Supply Voltage, V_{IN} ----- +2.5V to +5.5V
- Operation Temperature Range----- -40°C to +85°C

Electrical Characteristics

($V_{CC}=5V, T_A=25^\circ\text{C}$, unless otherwise specified.)

Parameter	Symbol	Conditions	Min	Typ	Max	Unit
Input Voltage	V_{CC}		2.5		5.5	V
Supply Current	I_{CC}	$I_{OUT}=0, V_{DIM}=V_{IN}$		200	400	μA
Shutdown Current	$I_{CC(SD)}$	$I_{OUT}=0, V_{DIM}=0V$		0.1	1.0	μA
ISEN Pin Voltage	V_{SEN}	$2.5V \leq V_{CC} \leq 5.0V$	0.188	0.20	0.212	V
Switching Frequency	F_{OSC}	Oscillator Free Running $2.5V \leq V_{CC} \leq 5.0V$	200	250	300	KHz
Threshold Enable	V_{DIMH}		1.5			V
Threshold Disable	V_{DIML}				0.6	V
Over-Voltage Protection	V_{SEN}	$2.5V \leq V_{CC} \leq 5.0V$	0.8		1.2	V
Analog Dimming Voltage Range	V_{DIM}	$V_{CC}=3.6V$	0.8		1.3	V

Typical Performance Curves

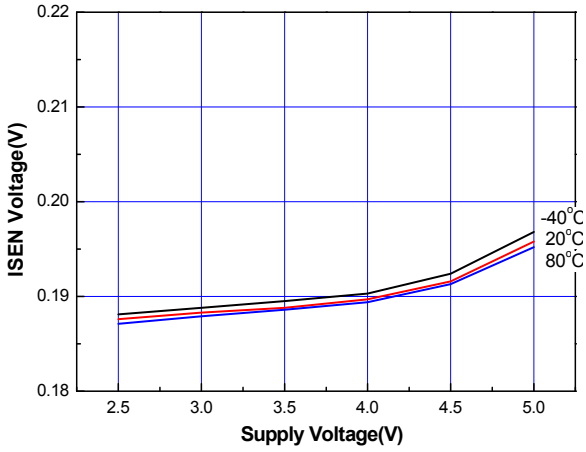

Figure 4. Supply Voltage vs. ISEN Voltage.

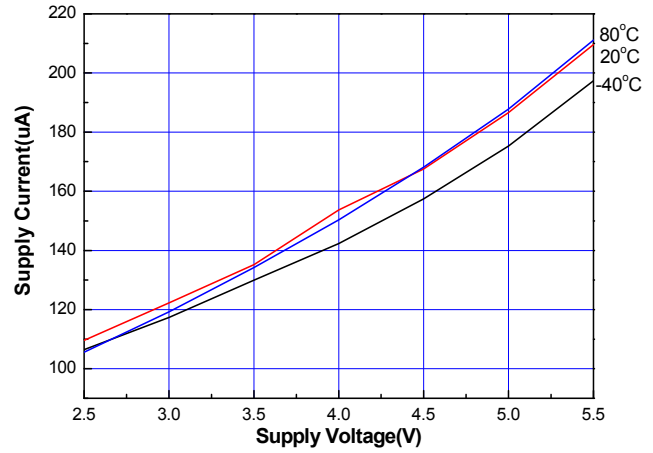

Figure 5. Supply Voltage vs. Supply Current.

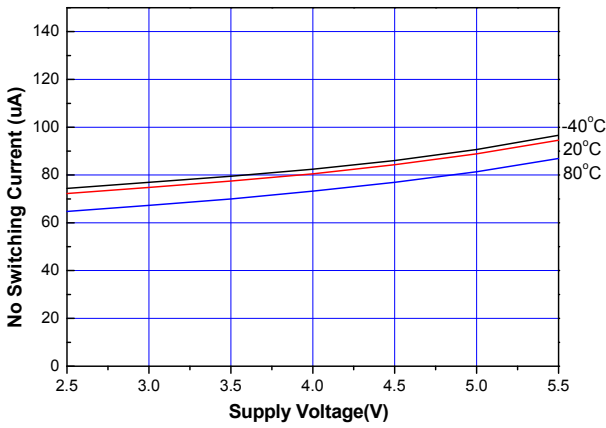

Figure 6. Supply Voltage vs. No Switching Current ($V_{ISEN}=0.3V$, Open Loop)

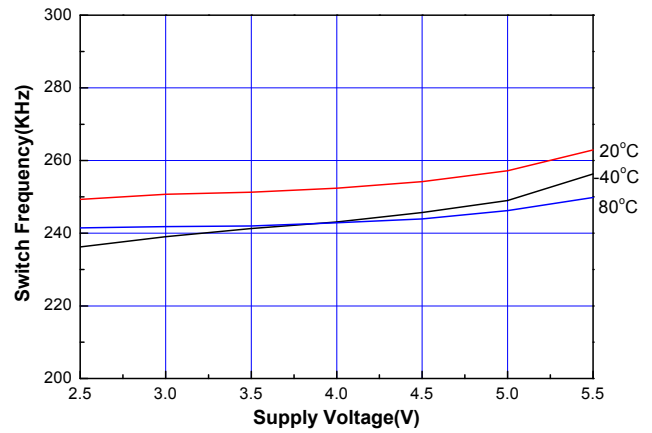

Figure 7. Supply Voltage vs. Frequency

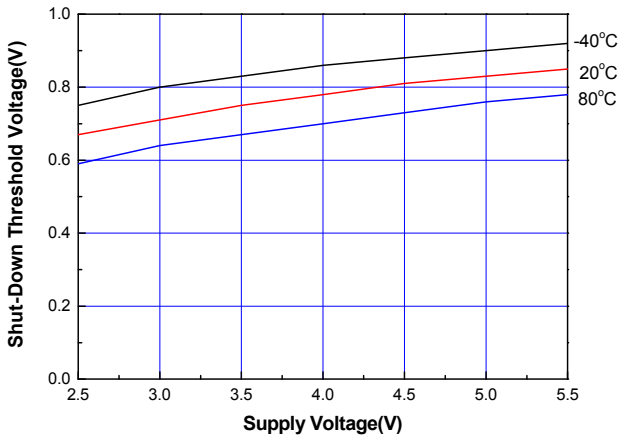

Figure 8. Supply Voltage vs. Shut-Down Threshold Voltage

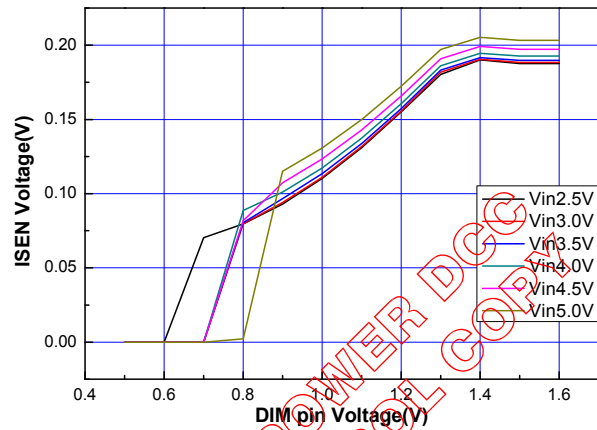

Figure 9. DIM Pin Voltage vs. ISEN Voltage

Applications Information

1. ENABLE

FP6738 is enabled when the voltage applied to DIM pin (Pin 3) is greater than 1.5V. A voltage of less than 0.6V disables the IC.

2. SOFTSTART

To avoid in-rush current to the load during turn-on, a soft-start function is implemented to provide reliable load operation. The soft start function is initiated when the voltage at DIM pin is greater than 0.8V. The soft-start time is determined by capacitor C_{COMP} connected to COMP pin (Pin 1).

3. LED CURRENT REGULATION

Once the IC is enabled, the LED current reaches the preset level and is sensed by resistor R_{SEN} connected to ISEN (Pin 2), the circuit begins to regulate LED current. The operating frequency is fixed thus minimizing EMI. An external resistor (R_{SEN}) connected from ISEN (pin 2) to GND sets the white LED current. The value of this resistor can be calculated from the formula below :

$$I_{LED} (mA) = \frac{200}{R_{SEN}(\Omega)}$$

4. DIMMING CONTROL

FP6738 allows for both analog and PWM dimming control.

A. Analog Dimming

Analog dimming control is achieved by varying the DC voltage level applied to DIM pin (Pin 3). The voltage range of 0.8V (minimum brightness) to 1.3V (maximum brightness) controls the panel brightness.

B. PWM Dimming

PWM dimming control is achieved by applying an external PWM signal of 100Hz to 200Hz with high voltage of greater than 1.5V and low voltage of less than 0.6V to DIM pin. In addition, a voltage of 1.5V to V_{CC} to DIM pin will output maximum current from FP6738. Varying the PWM duty cycle controls the panel brightness.

5. PROTECTION FEATURES

A. Thermal Protection

If the junction temperature exceeds 150°C, the thermal protection circuit shuts off the IC. When the junction temperature drops below 120°C, the device becomes functional again. If DIM pin is still high, the LED driver will turn on. Otherwise, it will remain in shutdown mode.

B. Over-Voltage Protection

In the event of an open-circuit, the over-voltage protection feature will be activated when the voltage at VSEN exceeds 1V. If this condition exists for duration of about 64µsec, the DRV pin (Pin 6) will be pulled low to prevent the external power MOSFET from switching. Toggle DIM pin to restart the IC.

6. MINIMUM OFF-TIME

Limiting the duty cycle of the external NMOS switch provides short-circuit protection. The DRV pin (Pin 6) output is pulled to low on every cycle for a preset time of about 70ns to 200ns.

7. INDUCTOR SELECTION

The LED driver is designed to operate in discontinuous mode to allow the use of a smaller inductor and capacitor. Proper selection of inductor is necessary to ensure that the converter still operates in this mode at the lowest V_{CC} and maximum load.

$$L_{CRIT} = \frac{1}{2} \times \frac{V_{OUT} \times D \times (1-D)^2 \times T}{I_{LED} (max)}$$

Where

$$D_{MAX} = 1 - \frac{V_{CC} (min)}{V_{OUT} (max)}$$

$$T = 4 \mu sec$$

The selected inductor has to be smaller than above value (L_{CRIT}) to ensure that the converter works in discontinuous mode.

The inductor peak current can be calculated by the following formula :

$$I_{PEAK} = \frac{V_{CC} \times T_{ON}}{L} \quad (A)$$

where

$$T_{ON} = T \times \left[\frac{(V_{OUT} - V_{CC}) \times 2 \times I_{LED}}{T \times V_{CC}^2} \right]^{1/2}$$

Outline Information

SOP- 8 Package (Unit: mm)

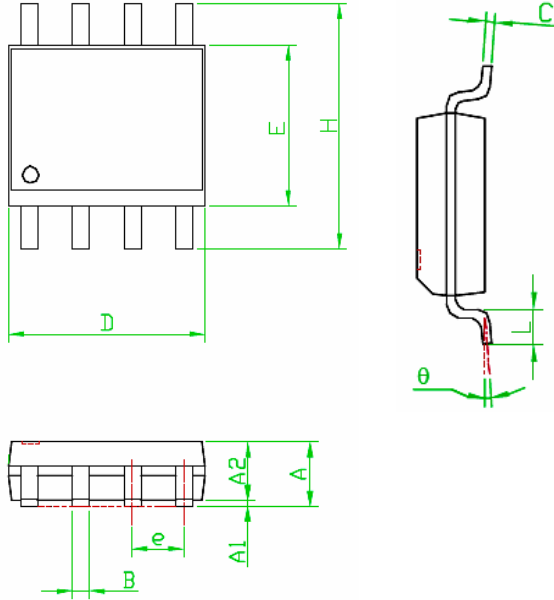

SYMBOLS UNIT	DIMENSION IN MILLIMETER		
	MIN	NOM	MAX
A	---	---	1.75
A1	0.10	---	0.25
A2	1.25	---	---
B	0.31	---	0.51
C	0.17	---	0.25
D	---	4.9	---
E	---	3.9	---
e	---	1.27	---
H	---	6.0	---
L	0.40	---	1.27
θ	0°	4°	8°

Note 1 : Followed From JEDEC MO-012-E.

TDFN-8 Package (2mm x 2mm) (Unit: mm)

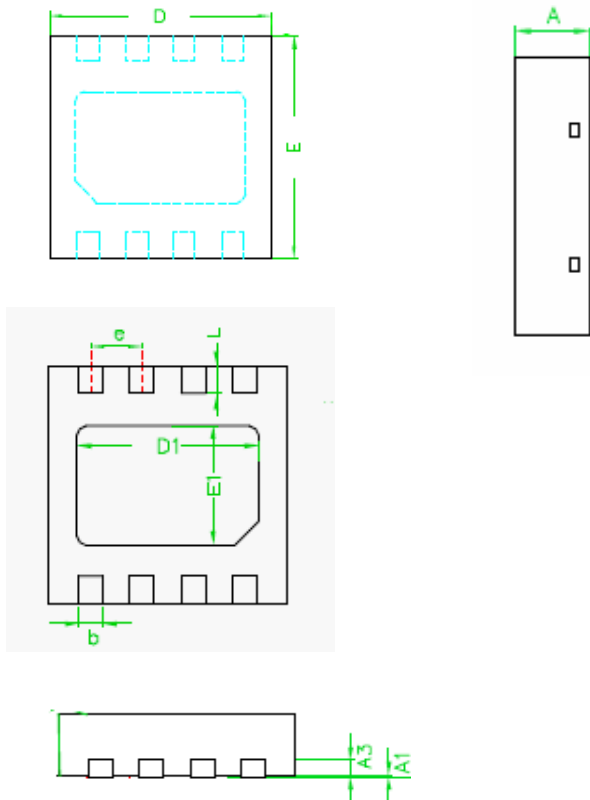

SYMBOLS UNIT	DIMENSION IN MILLIMETER		
	MIN	NOM	MAX
A	0.70	0.75	0.80
A1	0.00	0.02	0.05
A3	0.20 REF		
b	0.18	0.25	0.30
D	2.00 BSC		
D1	---	1.60BSC	---
E	2.00 BSC		
E1	---	1.00BSC	---
e	0.50 BSC		
L	0.30	0.40	0.50

Note 1 : Refer To JEDEC STD. MO-229-C

Life Support Policy

Fitipower's products are not authorized for use as critical components in life support devices or other medical systems.